

ISO 9001  
CE

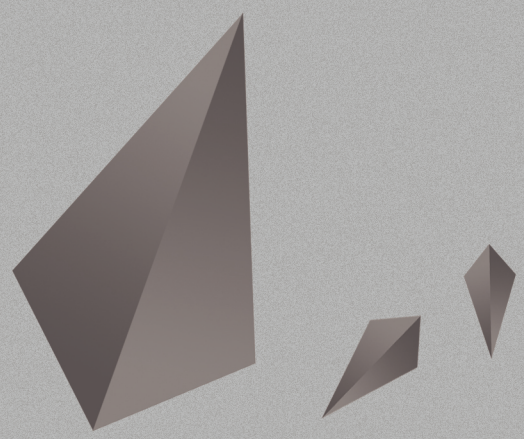

---

# Hydraulic Breaker MANUAL BOOK

---

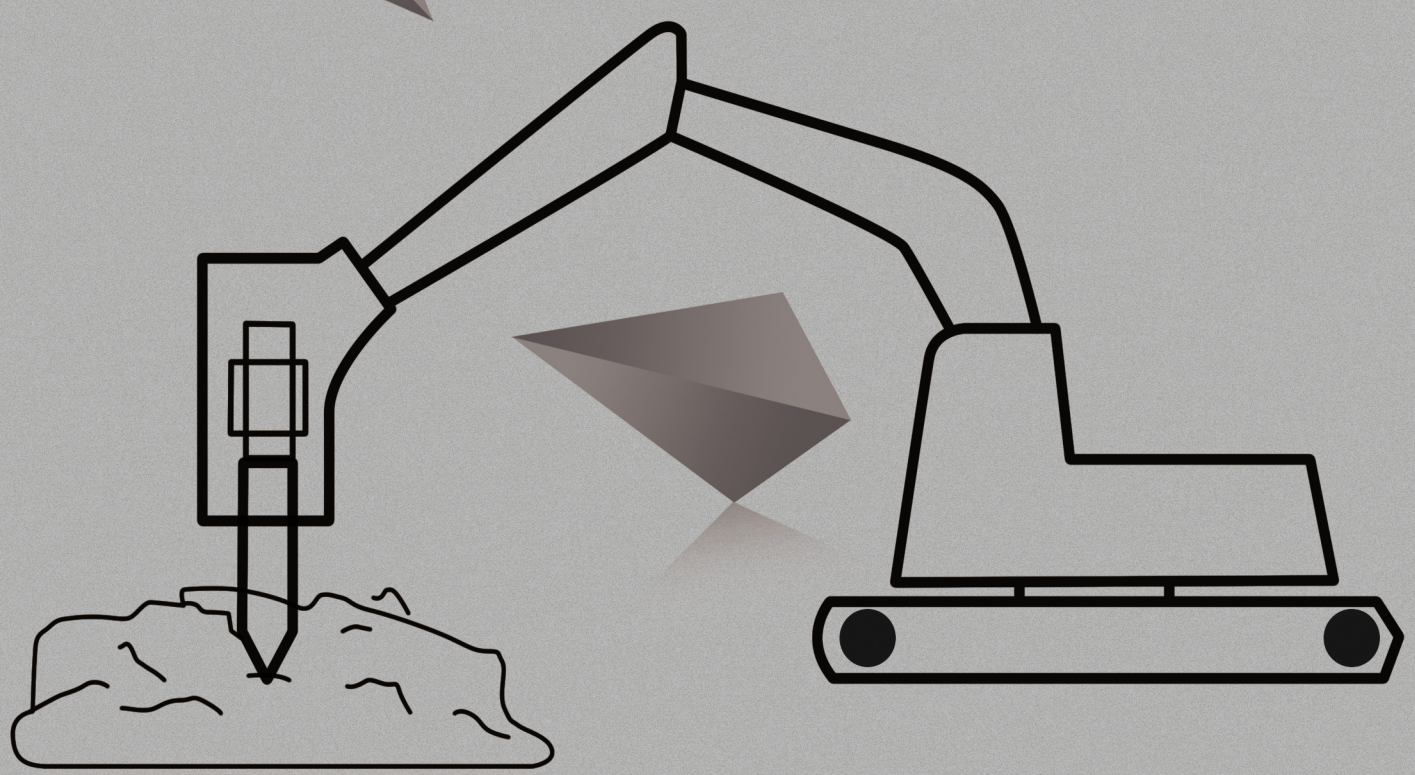

## □ Foreword

We appreciate your purchasing our hydraulic breakers.

This manual explains the correct handling methods, inspection, repair, operation, assembly and disassembly in order to use your hydraulic breaker safely and efficiently.

Also, this manual fully illustrates all information you need to achieve the best performance and minimize down time of your hydraulic breaker.

Before using this hydraulic breaker, be sure to read and fully understand this manual.

If you do not follow this manual, a serious accident can be occurred.

### WARNING

- The operator should read and fully understand this manual before installing, repairing or operating this hydraulic breaker.
- This manual should be kept near the hydraulic breaker, and those who use or manage the hydraulic breaker should read it periodically.
- When this hydraulic breaker is used carelessly, a serious accident can occur such as seriously injury or kill a person.
- If this manual is lost or damaged, please contact to the dealer.

**Foreword**

**Contents**

<b>1. Safety Information</b> -----	<b>3-4</b>
<b>2. Specification</b> -----	<b>5</b>
<b>3. Structure and Working principle</b> -----	<b>6-13</b>
<b>4. Installation and Removal</b> -----	<b>14-18</b>
4-1 Fundamental circuits	
4-2 General view	
4-3 Installation	
4-4 Removal	
<b>5. Maintenance</b> -----	<b>19-38</b>
5-1 Serial numbering system	
5-2 Safety label	
5-3 Moving and lifting	
5-4 Maintenance intervals	
5-5 Hydraulic oil	
5-6 Greasing	
5-7 Inspection and charging of nitrogen gas	
5-7-1 Back head	
5-7-2 Accumulator	
5-8 Pressure setting	
5-9 Seal inspection	
5-10 Wear inspection	
5-11 Inspection and replacement of through bolt	
5-12 Torque table	
5-13 Storage	
<b>6. Operation</b> -----	<b>39-44</b>
6-1 Tool installation	
6-2 Safety operation	
6-3 Function of adjuster	
6-3-1 Cylinder adjuster	
6-3-2 Valve adjuster	
<b>7. Trouble shooting</b> -----	<b>45-46</b>
<b>8. Tool selection</b> -----	<b>47-52</b>
8-1 Guide to tool choice	
8-2 Tool claim judgment	

## 1. Safety Information

### ■ Before operation

Many accident are caused by disregarding the basic rule of installation, operation and repair or by neglecting the inspection before operation

Before operating or repairing this hydraulic breaker, be sure to read and fully understand the preventive methods and warnings described on the hydraulic breaker or in this manual.

Safety labels and messages are classified as below so that the user may understand the warnings on the hydraulic breaker or in this manual.

#### DANGER

- Indicates an seriously dangerous situation which, if not avoided, will result in death or serious injury.
- This signal is to be limited to the most extreme situation.

#### WARNING

- Indicates a potentially dangerous situation which, if not avoided, could result in death or serious injury.

#### CAUTION

- Indicates a potentially dangerous situation which, if not avoided, will result in minor injury.

#### NOTICE

- Signs is used to indicate a statement of company policy directly or indirectly related to the personnel safety or property protection.

### ■ Specified works

This hydraulic breaker can be used for breaking, demolishing and drilling in mines, stone breaking or building engineering work.

#### WARNING

- **Do not use this hydraulic breaker for other works except the specified works.**
- **Wear the protective tools for safety**
  - Wear the clothes so that your body would not be caught by the projection of the base machine or the any lever or pulled by the machine.
  - Wear the helmet, safety shoes, earplug, etc. If necessary, wear a dustproof mask, protective glasses and gloves.
  - Usually clean the machine and keep a clear environment for working.

**⚠ WARNING**

- Keep the cautions and take a preventive measure for safety.
- 
- **Observance of safety rules in work place**
    - Observe all the rules, cautions and procedures for safety when the hydraulic breaker is operated or repaired.
    - Fulfill the work according to the signals already decided when cooperative work or work by guide is done.
  - **Inspection for safety devices**
    - When the work is stopped or finished, be sure to set the safety lock of operation with for the hydraulic breaker.
    - When the operator gets out from the base machine, be sure to put the hydraulic breaker on the ground and stop the engine of base machine.
  - **Be careful of the hydraulic oil pressure**
    - Before disconnecting or connecting hydraulic breaker, stop the engine of base machine, close stop valves “IN” and “OUT” connection, then operate the control lever to release pressure trapped in the hoses and wait ten(10) minutes.
  - **Safety from flying chips of rock during hydraulic breaker operation**
    - Protect yourself and your neighborhood against flying chips of rock.  
Do not operate the hydraulic breaker or base machine if someone is too close.
    - Keep the base machine’s cab doors and windows closed during operation.  
Windows bars are recommended to protect the windows from flying chips of rock.

## 2. Specification

Contents Model		45	53	68	75	85	100	125	135	140
Body Weight	kg	67	85	152	210	278	475	616	846	916
	lbs	148	187	335	463	613	1047	1358	1865	2019
Total Weight (Side/Top/Box)	kg	91/91/125	154/154/151	259/339/357	331/405/446	554/633/729	757/862/1003	1273/1304/1367	1649/1843/1889	1763/2055/2007
Length (Side)	mm	1086	1174	1369	1511	1731	1896	2282	2419	2476
	inch	42.76	46.22	53.90	59.49	68.15	74.65	89.84	95.24	97.48
Width (Side)	mm	215	230	295	295	390	390	480	575	575
	inch	8.46	9.06	11.61	11.61	15.35	15.35	18.90	22.64	22.64
Operating pressure	kg/cm <sup>2</sup>	90-120	90-120	110-140	120-150	130-160	150-170	150-170	160-180	160-180
	psi	1280-1706	1280-1706	1564-1990	1706-2133	1848-2275	2133-2417	2133-2417	2275-2559	2275-2559
	bar	88-117	88-117	108-137	118-147	127-157	147-167	147-167	157-176	157-176
Hydraulic flow range	L/min	20-30	25-50	40-70	50-90	60-100	80-110	90-120	130-150	120-180
	gal/min	5-8	6.6-13.2	10.5-18.5	13.1-23.6	15.8-26.3	21.1-29.1	23.7-31.7	34.3-39.6	31.7-47.6
Impact	bpm	700-1200	600-1100	500-900	400-800	400-800	350-700	350-650	400-800	350-500
Diameter of hose	mm	12.7	12.7	12.7	12.7	19.05	19.05	25.4	25.4	25.4
	inch	1/2	1/2	1/2	1/2	3/4	3/4	1	1	1
Diameter of Tool	mm	45	53	68	75	85	100	125	135	140
	inch	1.77	2.08	2.68	2.95	3.35	3.94	4.92	5.31	5.51
Suitable	ton	1.2-3.0	2.5-4.5	4-7	6-9	7-14	10-15	15-18	18-26	18-26

Contents		140A	150	155	165	165F	175	185F	195	210
Body Weight	kg	952	1088	1309	1438	1586	1929	2411	2626	3396
	lbs	2099	2399	2886	3170	3496	4253	5315	5789	7487
Total Weight	kg	1805/2090/2007	2214/2376/2453	2573/2750/2964	2747/3152/2912	3273/3443-2917	3901/4053/3898	4376/4809	5039/5164	6683/6993
Length (Side)	mm	2476	2636	2772	2816	2816	3180	3320	3416	3656
	inch	97.48	103.78	109.13	110.87	110.87	125.20	130.71	134.49	143.94
Width (Side)	mm	575	665	665	665	665	764	764	764	864
	inch	22.64	26.18	26.18	26.18	26.18	30.08	30.08	30.08	34.02
Operating pressure	kg/cm <sup>2</sup>	160-180	160-180	180-200	180-200	180-200	180-200	190-220	190-220	200-240
	psi	2275-2559	2275-2559	2559-2844	2559-2844	2559-2844	2559-2844	2702-3128	2702-3128	2844-3413
	bar	157-176	157-176	176-196	176-196	176-196	176-196	186-216	186-216	196-235
Hydraulic flow range	L/min	120-180	150-190	200-260	200-260	200-260	210-290	220-270	220-290	290-350
	gal/min	31.7-47.6	39.6-50.2	52.8-68.6	52.8-68.6	52.8-68.6	55.44-76.56	58.08-71.28	58.08-76.56	76.56-92.4
Impact	bpm	350-500	350-700	250-400	250-400	250-380	200-350	200-250	180-200	150-200
Diameter of hose	mm	25.4	25.4	31.75	31.75	31.75	31.75	31.75	31.75	31.75
	inch	1	1	1-1/4	1-1/4	1-1/4	1-1/4	1-1/4	1-1/4	1-1/4
Diameter of Tool	mm	140	150	155	165	165	175	185	195	210
	inch	5.51	5.91	6.1	6.5	6.5	6.89	7.28	7.68	8.27
Suitable Carrier	ton	18-26	27-35	28-36	30-40	30-40	35-40	35-45	40-55	60-80

### 3. Structure and Working principle

Model: 45/53/68/75/85/100 /140/140A/155/165/165F/175 (Inward value type)

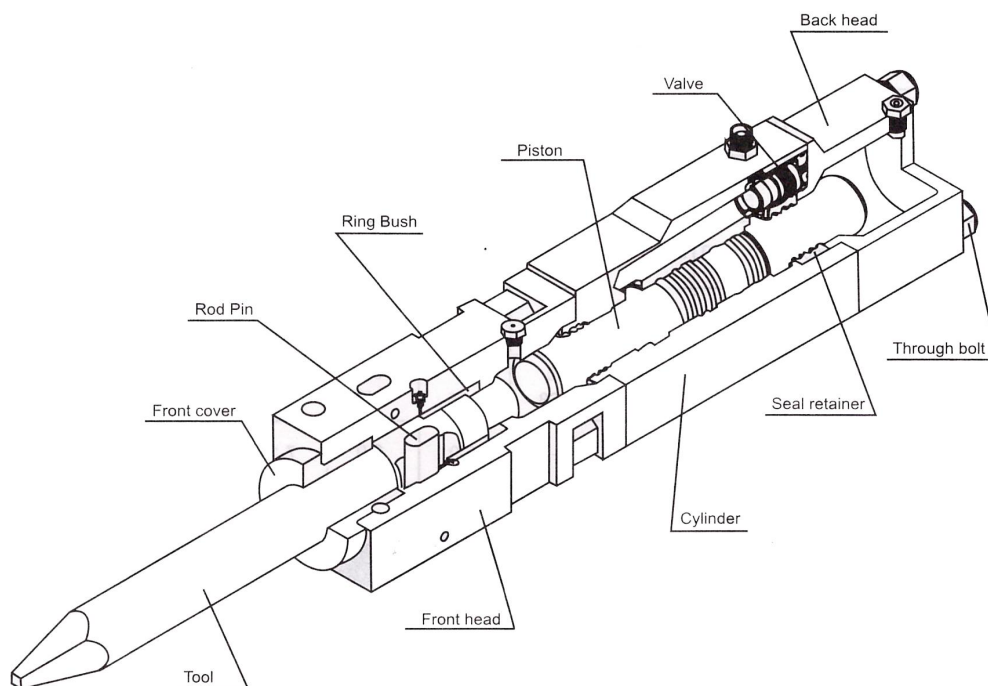

#### 1) **Cylinder**

This contains the moving piston which strikes the tool. The seals for both ends of the piston are also located in the cylinder. The seals for the upper end of the piston are located in a removable seal retainer while the seals for the lower end of the piston are located in grooves machined directly into the cylinder.

#### 2) **Piston**

The piston transfers impact power to the tool, generated by hydraulic power.

#### 3) **Seal retainer**

The seal retainer has oil seals to seal Nitrogen(N<sub>2</sub>) gas in back head, and to prevent hydraulic oil leakage.

#### 4) **Valve**

The valve controls reciprocates piston action with hydraulic fluid distribution.

#### 5) **Front head assembly**

This retains the tools, using the tool pins.

By removing these pins, the tool can be changed.

**6) Ring Bush**

This guides the tool, Ring Bush limits the uppermost position of the tool. It is consumable parts, which should be checked for wear limits. If needed, they should be replaced.

**7) Tool**

This transfers piston impact power to the objects. We recommend that various tool shapes according to working circumstance.

**8) Rod Pin**

This is installed on the front head, and prevents the tool from coming off.

**9) Back head assembly**

This contains the cushion chamber charged with Nitrogen(N<sub>2</sub>) gas that is compressed during upward strokes of the piston, and serves to provide maximum absorption recoil, efficiency storing this energy for the next blow.

**10) Through bolts**

These are used to assemble the front head, the cylinder and the back head. They have to be constantly tightened to specified torque. Inspect the bolts for loosening, and retighten them weekly.

### 1) Set Up

The relation between the area (A1) affecting the pressure from the upper chamber of the piston and the area (A2) affecting the pressure from the lower chamber of piston is  $A1 > A2$  and high pressure always applies to A2. When A1 change from high to low pressure or vice versa, Piston C1 reciprocates. Inside of back head is change with the high pressure gas and gas energy stored in the up stroke of the C1 effectively acts on the piston C1 during the impact.

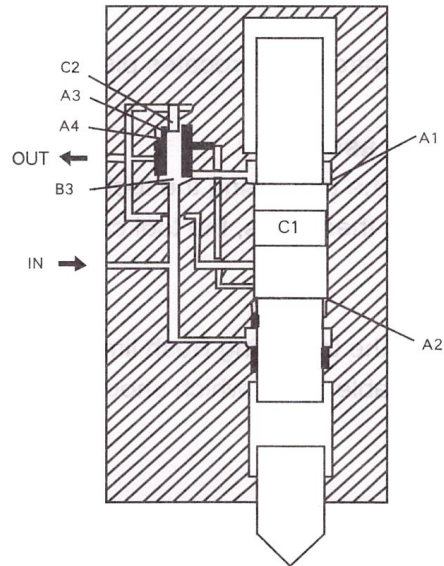

### 2) Piston Conversion

When piston C1 reaches top head center, high pressure oil from valve high-pressure port B3 applies to upper chamber of the piston A1 to change the piston stroke from upstroke to impact. At this time the relation between the area (A3) affecting the pressure from valve high pressure changes and the area (A4) of the valve change chamber is  $A4 > A3$ . The high pressure always applies to A4 and valve C2 remains in the upper position.

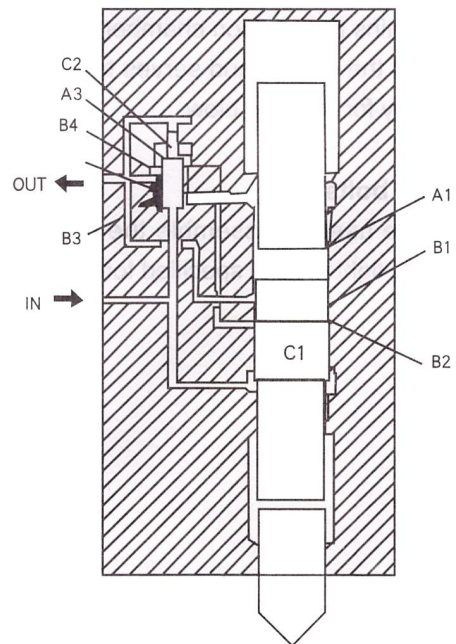

### 3) Valve Conversion

When cylinder low pressure port B1 is connected to cylinder change port B2, the pressure in valve change port B4 lowers. As force acting port C2 is the only pressure in valve high pressure port B3 is closed and valve low pressure port B5 is opened to the lower the pressure in the upper chamber of the piston A1.

#### 4) Impact

When piston C1 reaches impact point, kinetic energy obtained by piston C1 during the impact stroke is transmitted to the tool for the impact energy required to hydraulic breaker. At this time, as high pressure applies only to the lower chamber of the piston A2, piston C1 starts reversing. Further, as high pressure applies only to the valve high pressure chamber A3, valve C2 is remaining in the lower position.

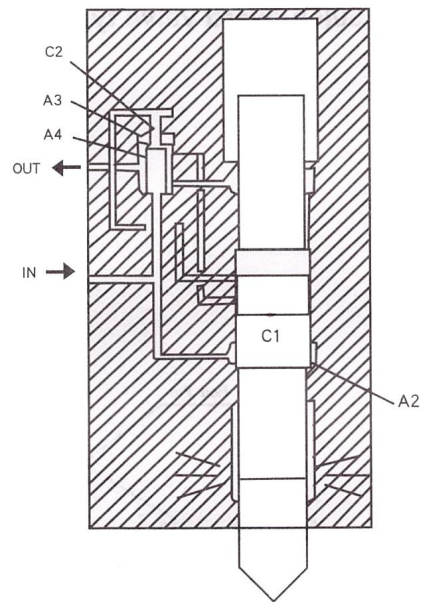

#### 5) Piston Rise

When cylinder change port B2 is connected to cylinder lower pressure port B1, high pressure oil applies to low pressure outlet port valve C2 this time valve low pressure port A1 this time valve low pressure port B5 is closed and valve high pressure B3 is opened the upper chamber of the piston A1 to rise the pressure in the lower chamber of the piston A1.

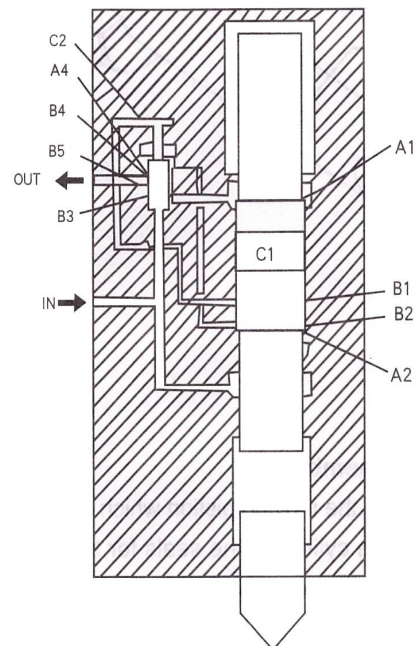

A1: Piston upper chamber

A2: Piston lower chamber

A3: Valve high pressure chamber

A4: Valve conversion chamber

B1: Cylinder low pressure port

B2: Cylinder conversion port

B3: Valve high pressure port

B4: Valve conversion port

B5: Valve low pressure port

C1: Piston

C2: Valve

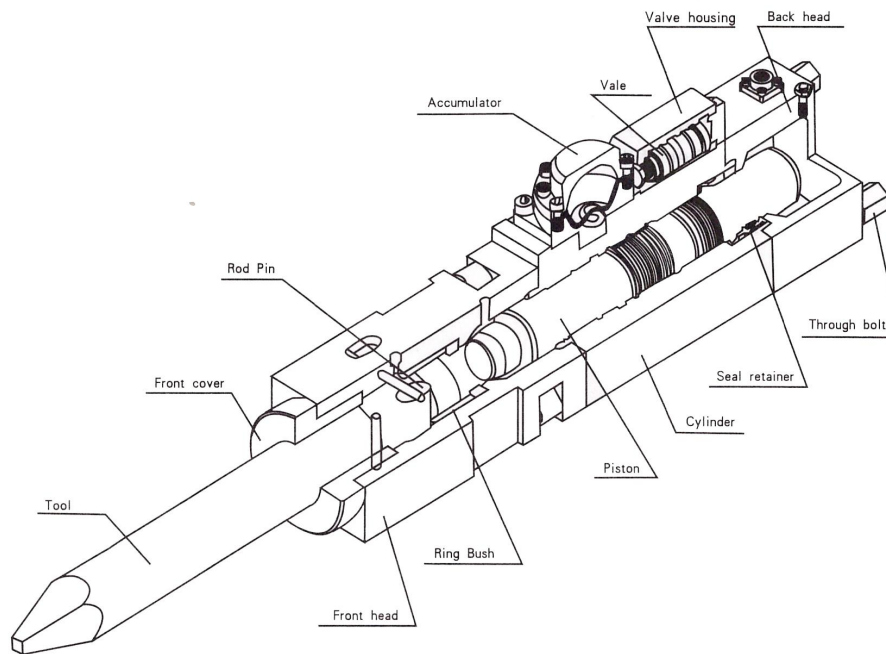
**Model: 135/ 150 (Outward value type)****1) Cylinder assembly**

This contains the moving piston which strikes the tool. The seals for both ends of the piston are also located in the cylinder. The seals for the upper end of the piston are located in a removable seal retainer while the seals for the lower end of the piston are located in grooves machined directly into the cylinder.

**2) Piston**

The piston transfers impact power to the tool, generated by hydraulic power.

**3) Seal retainer**

The seal retainer has oil seals to seal Nitrogen(N<sub>2</sub>) gas in back head, and to prevent hydraulic oil leakage.

**4) Valve housing**

This guides the main valve movement.

**5) Valve**

The valve controls reciprocates piston action with hydraulic fluid distribution.

**6) Valve adjuster**

When the base machine supplies insufficiently hydraulic oil to hydraulic breaker, this valve adjuster can obtain the rated working pressure by reducing number of blows, and in the reverse, when excessive oil flow from base machine, the

---

increasing number of blows, by this valve adjuster, can keep the rated working pressure.

**7) Cylinder adjuster**

Turn the setting screw clockwise to decrease rate of hydraulic breaker, counterclockwise to increase blows rate of hydraulic breaker.

**8) Accumulator assembly**

The accumulator is a gas charged storage device designed to hold a reserve quantity of hydraulic fluid under pressure.

In a hydraulic circuit, minor variations or lags in pump output that might otherwise cause unsteady or irregular operation are made up from the supply of pressurized oil in the accumulator.

Accumulator is solidly constructed to resist high operating pressure.

**9) Front head assembly**

This retains the tools, using the tool pins.

By removing these pins, the tool can be changed.

**10) Ring Bush**

This guides the tool, Ring Bush limits the uppermost position of the tool.

It is consumable parts, which should be checked for wear limits. If needed, they should be replaced.

**11) Tool**

This transfers piston impact power to the objects.

We recommend that various tool shapes according to working circumstance.

**12) Rod Pin**

This is installed on the front head, and prevents the tool from coming off.

**13) Back head assembly**

This contains the cushion chamber charged with Nitrogen(N<sub>2</sub>) gas that is compressed during upward strokes of the piston, and serves to provide maximum absorption recoil, efficiency storing this energy for the next blow.

**14) Through bolts**

These are used to assemble the front head, the cylinder and the back head. They have to be constantly tightened to specified torque. Inspect the bolts for loosening, and retighten them weekly.

### 1) Set Up

Chambers C3, C2 always maintain low pressure, because they are connected to the output line. Chambers V3, V1, C1 and accumulator always maintain high pressure, because they are connected to the input line. Chamber V2 pressure is changed to low pressure or high pressure depending on piston position.

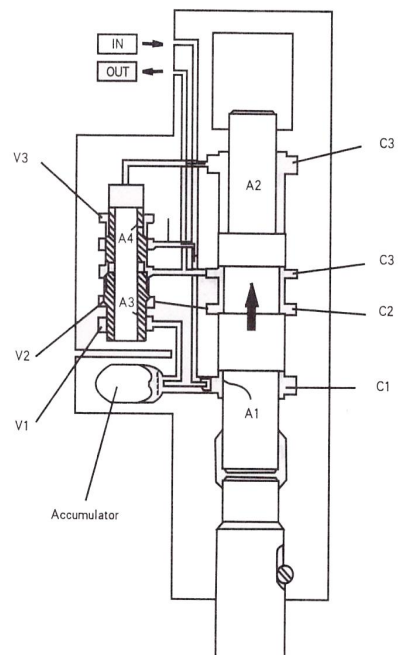

Piston Rise

### 2) Piston Rise

Oil enters to “IN” port, and begins to accumulate force to raise piston, hydraulic force is applied on A1 of piston lower flange, and piston begins to rise.

When the piston begins to rise, oil from C4 chamber returns to the output line through the control valve.

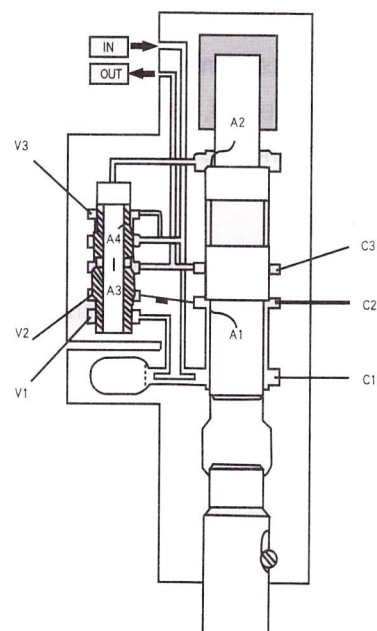

Valve Rise

### 3) Valve Rise

When piston rises to around upper limits, A1 of piston lower flange reaches chamber C2, and the back head nitrogen (N<sub>2</sub>) gas is compressed.

At this time, oil from chamber C2 goes to chamber V2.

A3 area is larger than A4 area, but applied pressure of area A3 is the same as applied pressure of area A4.

Therefore, the valve begins to rise, because of the area difference between A4 and A3.

#### 4) Piston Descent

When the valve reaches the upper limits, chamber C4 becomes high pressure area, because oil from the working pump goes to chamber C2, through the control valve holes. A2 area is larger than A1 area, but pressure applied to A1.

Therefore, the piston begins to descend, because of the area difference between A2 and A1.

At this time, piston descent speed is accelerated by compressed nitrogen (N<sub>2</sub>) gas pressure and piston weight.

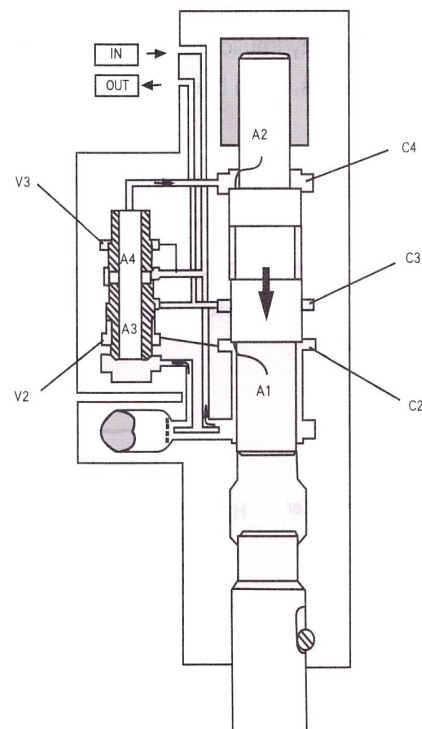

Piston Descent

#### 5) Impact

Chamber V2 is changed in low pressure as chamber C2 is connected with C3 during piston descent. But V3 is always high pressure. Therefore, the valve begins to descend.

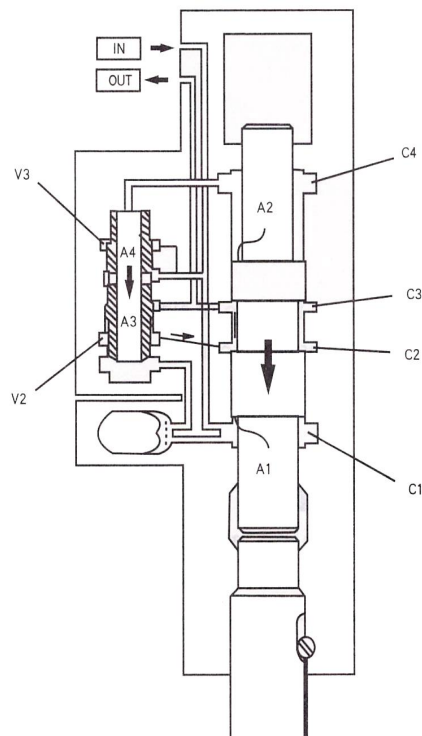

Impact

#### 6) Continuous Strike

After the piston strikes the tool, the status of all circuits are changed to “Piston Raising”. The piston begins to raise via status flowing into “IN” port, and the cycle is repeated again.

## 4. Installation and Removal

### 4-1. Fundamental circuit

When piping the hydraulic lines on base machine, it is important to know the fundamental circuit to which the piping belongs. Then the piping can be connected correctly, properly and quickly.

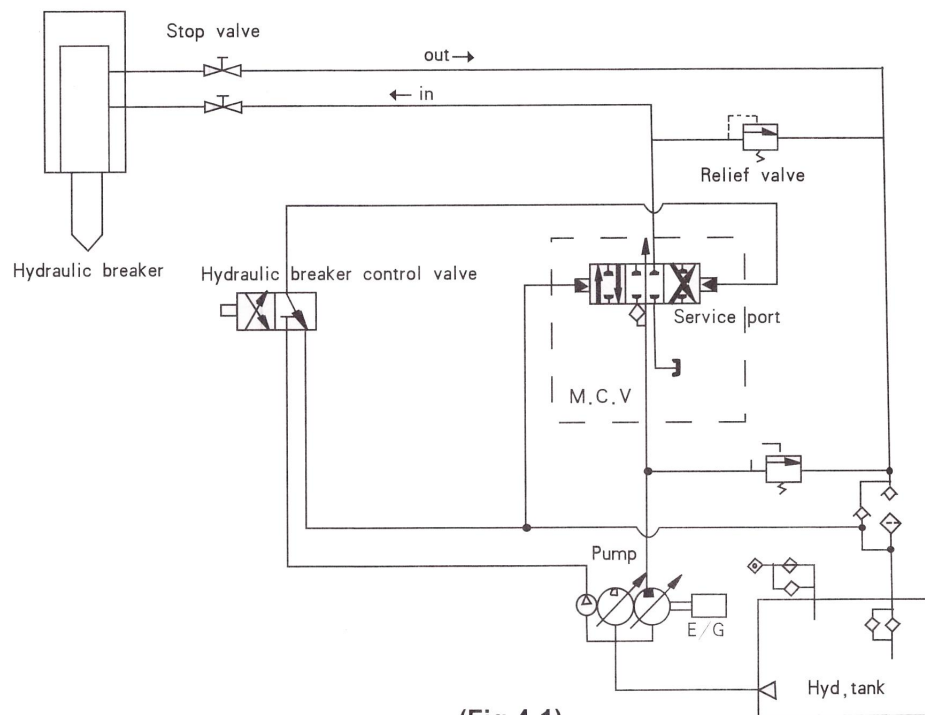

(Fig.4-1)

Fig.4-1 is shown the one of simplest hydraulic circuit in case of installation a service port into the main control valve of base machine.

#### NOTICE

- If the piping method is different with Fig.4-1, consult us or attachment manufacturer.

## 4-2. General view

### NOTICE

- Check the piping lines for correctness of such as pressure, flows or pressure loss, if the hydraulic pipe once are installed in the base machine.
- A pressure control valve has to be installed, if there is no pressure control valve on the main control valve of base machine.

Standard view of installation is as shown in Fig.4-2

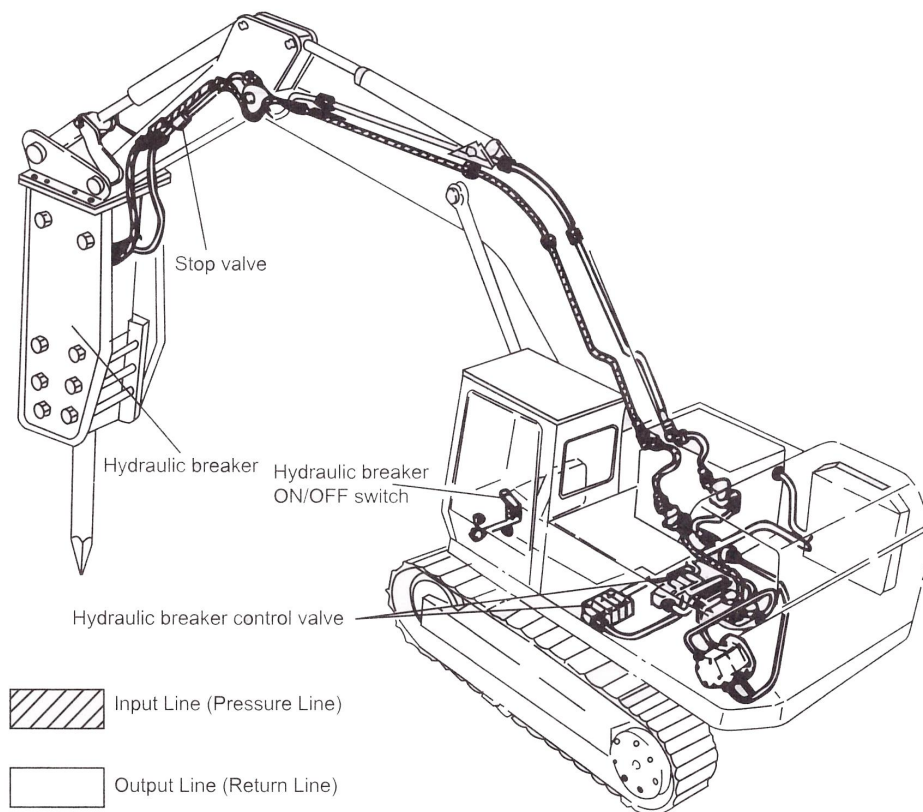

(Fig.4-2)

### 4-3. Installation

#### ⚠ CAUTION

- Never Insert your hand or fingers into the pin hole.

#### ⚠ WARNING

- While aligning the arm hole, or moving the bucket, make sure that there are no person in the vicinity of arm or bucket of base machine.
- It is dangerous to move the base machine suddenly during installation.
- Wear the safety shoes to protect feet.

#### NOTICE

- Be careful so that dust may not enter the hydraulic breaker and base machine.
- Install or remove the hydraulic breaker on horizontal ground without mud or dust.

- 1) Set the hydraulic breaker on horizontal ground.
- 2) Remove the bucket from the base machine after disassembling the two pins.

#### NOTICE

- If the bucket cylinder is retracted, the installation will be easier.

- 3) Move the base machine in the vicinity of hydraulic breaker, and align the pin hole of arm with the pin hole of hydraulic breaker, and then, insert the pins.
- 4) After the arm pin is inserted, lift the boom, insert the hydraulic breaker on the wood blocks like 4-3-3. Extend the bucket cylinder, fit it to the bucket link's hole and insert the pins.
- 5) Install the stop rings, align the bolt holes and insert the bolts, mutually lock double nut.

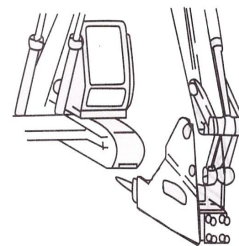

(4-3-1)



(4-3-2)

#### NOTICE

- If the stop rings are secured with one nut only, the service life of the bolt may be shortened or the bolt may be loosened out very quickly.

- 6) Stop the engine of the base machine, turn off the main switch and discharge the air pressure in the hydraulic oil tank.
- 7) Remove the union caps from the hydraulic breaker pipe of the arm end, and connect the hoses after disassembling the hose plug.

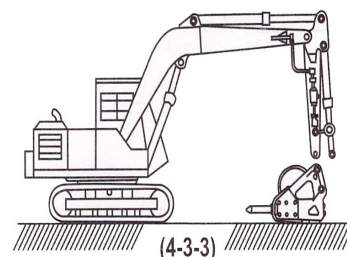

(4-3-3)

**NOTICE**

- Do not allow the oil to drop onto the ground.
- Store the removed union cap and hose plug in the tool box.
- When installing or removing the oil hose and union cap, clean them fully to prevent the dust and mud from entering the hydraulic breaker of the base machine.

- 8) Connect the hoses to stop valve at both sides of arm.
- 9) Turn on the engine of the base machine, left the boom, operate the bucket cylinder and check the hose of hydraulic breaker is connected correctly.
- 10) Starts warm up the base machine.

**HYD' Hose SPEC**

Model	Hose Diameter (inch)	Length (mm)	Working Pressure (bar)
45/53/68/75	1/2	1450	140
85/100	3/4	1850	170
135/140(A)	1	2300	180
150/155	1	2500	180
165(F)	1-1/4	2800	190
175	1-1/4	3000	200

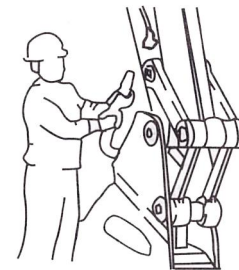

(4-3-4)

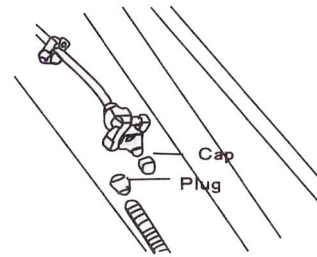

(4-3-5)

**NOTICE**

- Warm up the base machine by idling for 5 minutes after starting the engine.
- Move the boom and arm for approx. 5 minutes after warm up operation to raise the hydraulic oil temperature of base machine.

- 11) Turn the stop valves to “ON” position.

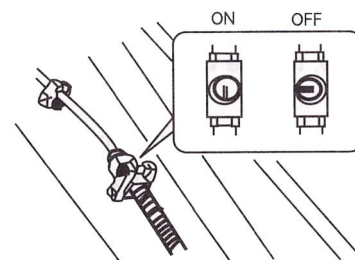
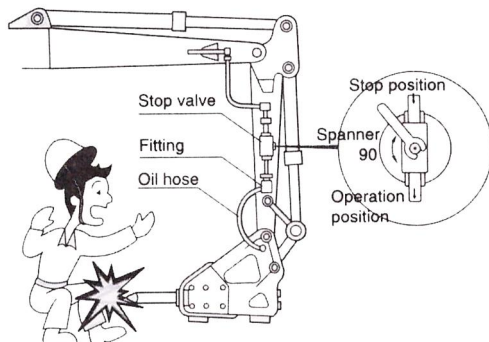

(4-3-6)

**CAUTION**

- The tool may come out under oil pressure in the pipe line. Do not stand near of hydraulic breaker.

#### 4-4. Removal

##### ⚠ CAUTION

- Personal injury can result from dropping pins during removal.

##### ⚠ WARNING

- Wear safety shoes to protect feet.

##### NOTICE

- Cover the hydraulic breaker already removed with sheet, and then store it in doors.

- 1) Set the hydraulic breaker on clean and horizontal ground. Lock the packing brake of base machine.

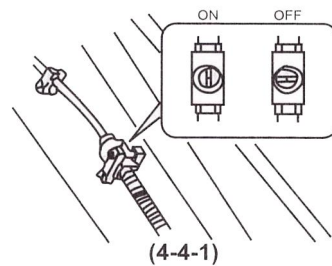

- 2) Stop the engine.

- 3) Turn stop valve to “OFF” position.

- 4) Disconnect hoses from stop valves. Ensure no leakage occurs from hoses and stop valves.

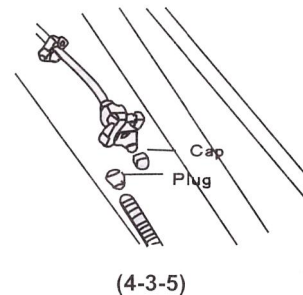

- 5) Apply union cap and plug to hose ends fittings to prevent contamination.

- 6) Remove pins fixing fasteners.

- 7) Remove pins.

- 8) When pins have been withdrawn, move operating joystick slightly, to take weight off remaining link pin.

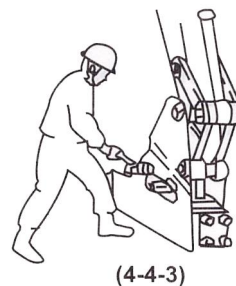

- 9) Lift arm away from hydraulic breaker so that hydraulic breaker can be carried away, or another attachment mounted on base machine.

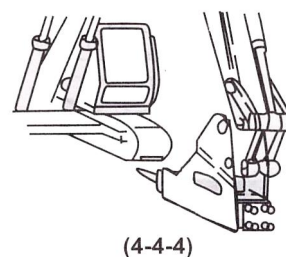

## 5. Maintenance

### 5-1. Important Reminder to operator

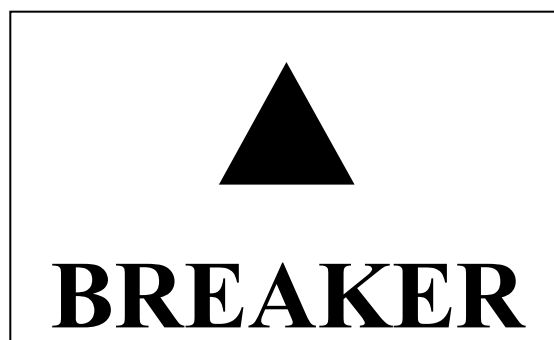

#### **PRECAUTIONS DURING USE OF HYDRAULIC BREAKER**

##### Before Operation

- Check the oil level in the tank
- Grease up Chisel
- Check bolts of looseness
- Charge Nitrogen (N<sub>2</sub>) Gas in Back Head and Accumulator to meet standard pressure required.





##### During Operation

- Avoid blank hitting
- Must place chisel vertically to surface
- Do not blow more than one minute on same spot
- Must replace new front cover once the gap between front cover and chisel is over the maximum wear allowance.
- Do not operate the breaker when the cylinder on the excavator is fully extended.

##### Storage

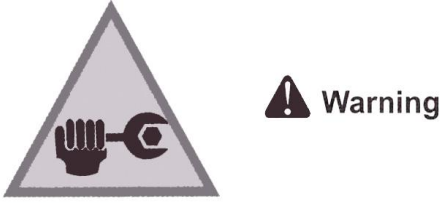
- When dismantling breaker, be sure to put plugs in.
- Foreign matters in piping will be the cause of trouble.
- Discharging Nitrogen (N<sub>2</sub>)
- Be sure to keep piston in the position of back head side

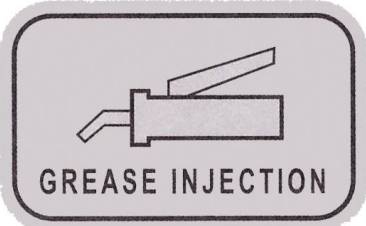
5-2. Safety label

	
<p>Stop! Personal protective equipment must be worn in this area. Consult your supervisor for instruction.</p>	<p>Read and understand technical manual before servicing this machine.</p>
	<p><b>Caution</b></p> <ul style="list-style-type: none"> <li>◆ Pressurized container!</li> <li>◆ Do not open without reading the operating manual or consulting the service personnel!</li> <li>◆ Use Nitrogen gas only!</li> </ul> <p>Optimum pressure: 55-60 kg/cm<sup>2</sup> (at 20°C)</p>
<p>Noise hazard wear approved ear protection in this area.</p>	
	
<p>Greasing label</p>	<p>Consult manual warning label</p>

### 5-3. Moving and lifting

**⚠ WARNING**

- Always use eye-bolts when lifting & moving the hydraulic breaker, after fasten up to bracket.
- Fasten the ropes to the shackles (four pieces) and lift the hydraulic breaker up
- Remove the eye-bolts before hydraulic breaker operation

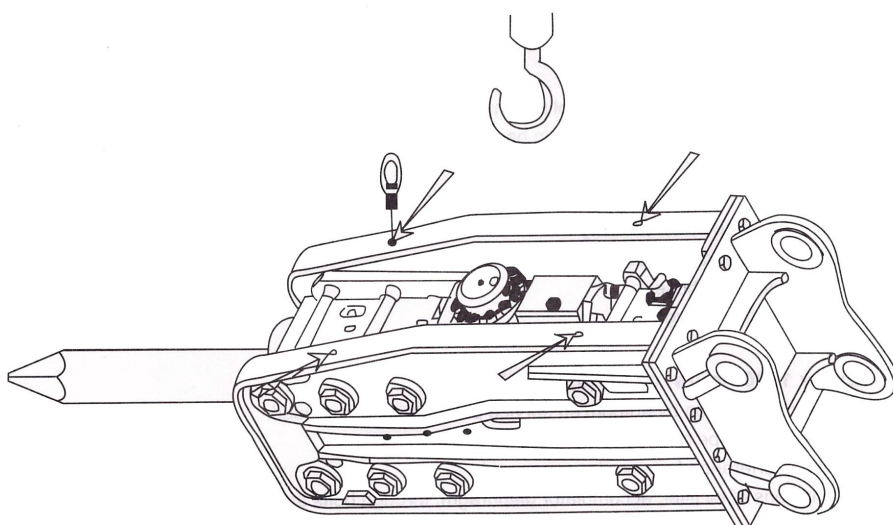

Model	Eye bolt size (mm)	Wire Rope Size (mm)
135/140/150/155/165	M24	φ 16
175	M30	φ 20

## 5-4. Maintenance intervals

### NOTICE

**Before hydraulic breaker operation, be sure to check the following points.**

#### ■ Every 3 hours

- Apply the grease in front head.
- Check hydraulic oil temperature, piping and hose connections, and working condition.
- Check tightness of fasteners.

#### ■ Every 10 hours, or Daily

- If rough skin on the total and tool pins have been found, it must be removed.
- Check the nitrogen gas pressure in back head.
- Retighten the bracket bolts.

#### ■ Every 50 hours, or Weekly

- Check the clearance between tool and front cover.
- Check hydraulic hoses.
- Retighten the through bolts.

#### ■ Every 1000 hours, or Six (6) months

- Factory inspection by authorized service personal recommended.
- All hydraulic pipe and hose connections.
- Hose interference from carrier movement.
- Conditions of oil filter, accumulator diaphragm, through bolts and tool pins.

#### ■ Every 2000 hours, or Annually

- All hydraulic pipe and hose connections.
- Hose interference with excavator boom.
- Conditions of oil filter, accumulator diaphragm, through bolts and tool pins.
- All seals.
- Conditions of piston, front cover, inner bush.

## 5-5. Hydraulic oil

### ■ Recommended hydraulic oil

Normally, any hydraulic oil originally intended for base machine can be used in the hydraulic breaker.

However oil viscosity must be checked timely, because the oil may be heated much more in the hydraulic breaker works than in normal excavator works.

When hydraulic breaker is used continuously the oil temperature normalizes at certain levels, depending on conditions and carrier.

At such temperatures, hydraulic oil viscosity should be 20-40 cST.

#### NOTICE

- Usually, the hydraulic oil temperature of hydraulic breaker and base machine must be controlled between 40°C and 60°C.
- When you operate the hydraulic breaker while the oil temperature exceeds 80°C, you must check the seals.

Maker	Hydraulic oil	
	ISO VG68	ISOVG46
ESSO	Nuto H68	Univis N46
SHELL	Tellus oil 68	Tellus oil 46
MOBILE	DTE 16	DTE 15
GULF	Harmony68	Harmony 46
	For hot weather use	For cold weather use

### ■ Replacement of hydraulic oil & filter

Contamination of hydraulic oil may result in part damage, not only in hydraulic breaker, but also in carrier main components. We recommend hydraulic oil and oil filters replacement as shown in the following table, which is based on 100% hydraulic breaker operation.

Hydraulic oil	First 250 hours Every 600 hours	Based on 100% hydraulic breaker operation
Oil filters	First 50 hours Every 100 hours	

### ■ Hydraulic oil viscosity

Hydraulic breaker must not be started if hydraulic oil viscosity exceeds 1000 cST, not operated when hydraulic oil viscosity falls 15 cST.

#### Oil viscosity too high

- Start up difficulty
- Operation stiffness
- Irregular hydraulic breaker impact
- Danger of cavitation in pumps and hydraulic breaker.
- Valve sticking
- If the filter is very contaminated, hydraulic components could be damaged, due to open bypass valve.

#### Oil viscosity too low

- Efficiency losses from internal leakage.
- Damage to seals, O-rings.
- Accelerated wearing of parts, because of decreased lubrication efficiency.

### ■ Cooling

Maximum permitted hydraulic oil temperature range in continuous hydraulic breaker use in 50-80 °C (120-175 °F), depending on viscosity of oil in the system.

Therefore, a reliable hydraulic oil thermometer is necessary.

If there is no thermometer on the carrier, one must be installed. Hydraulic oil temperature depends on ambient conditions, carrier cooling system efficiency, and on hydraulic breaker use.

When hydraulic breaker is used continuously, it is necessary to have a cooling system with extra cooling capacity, as compared with normal excavation work.

### ■ Hydraulic oil temperature

The normal temperature of hydraulic oil operating is -20 °C (-4 °F), the hydraulic oil have to be preheated before operation, in order to avoid breakage of the accumulator diaphragm.

To preheat hydraulic oil, operate the base machine (without running hydraulic breaker), until oil temperature rises to specified temperature range.

During operation, oil will remain warm.

If hydraulic oil temperature exceeds specified limits, please stop equipment and don't restart operation until oil has cooled to specified operating temperature range.

## 5-6. Greasing

### **⚠ WARNING**

- **Insufficient greasing may cause abnormal wear of front cover and tool, and tool breakage.**

- Apply grease to grease nipple on front head every 3 hours.
- Adopt grease interval and amounts to tool wear rates and working conditions.

### **⚠ WARNING**

- Tool shank must be well lubricated before installed in front head.
- Greasing label

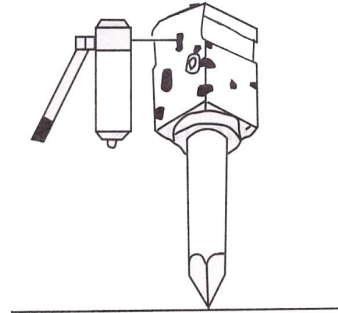
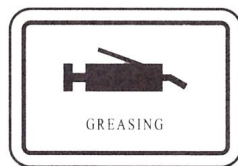

### **NOTICE**

- While greasing, hydraulic breaker must be upright against the tool, to ensure that grease will penetrate between tool and inner bush.

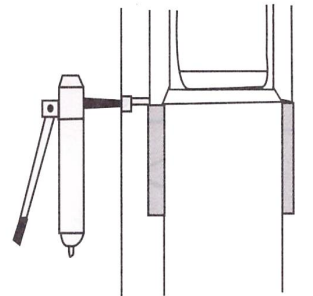

### Recommended lubricant grease (NIGI NO.2)

Maker	Grease
Esso	Beacon Q2
Shell	Retinax AM
Mobile	Mobile Grease special

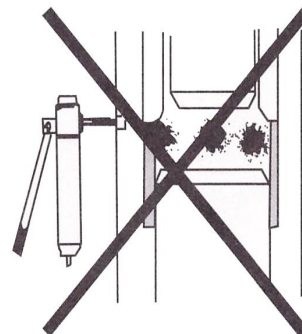

## 5-7. Inspection and charging of Nitrogen (N<sub>2</sub>) gas

### 5-7.1 Back head

#### ⚠ CAUTION

- Do not stand in front of the tool while nitrogen gas is charged in back head.
- The nitrogen gas in back head must be discharged completely when a through bolt is replaced or a main body is disassembled.

#### ⚠ WARNING

- Use nitrogen gas only
- The temperature of the hydraulic breaker main body must normal when inspection or charging of nitrogen gas in back head.

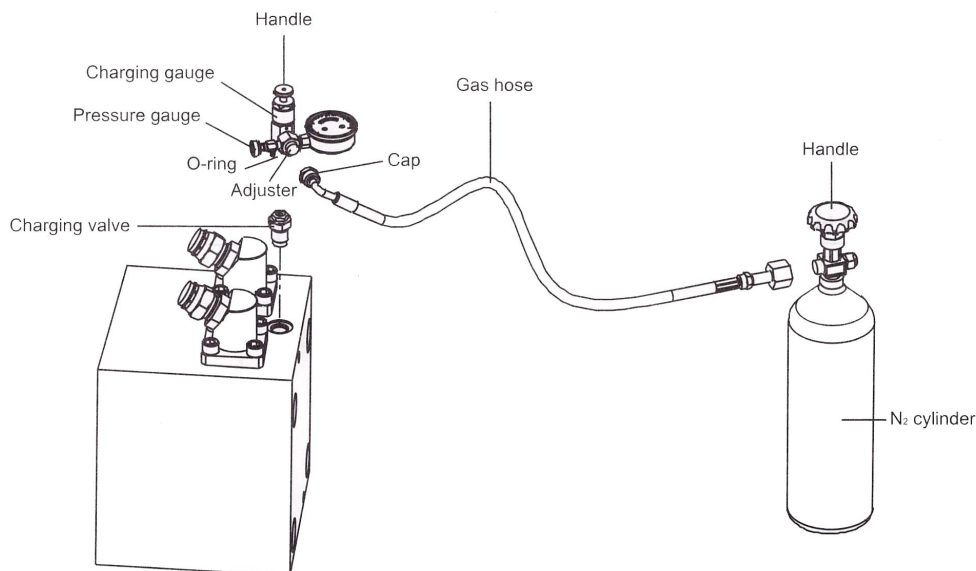

- (1) Connect gas hose to N<sub>2</sub> gas cylinder.
- (2) Turn the handle of charging gauge counterclockwise before install the charging gauge.
- (3) Install charging gauge to charging valve. (Make sure that O-rings are installed on charging gauge.)
- (4) Connect other end of gas hose to charging gauge.
- (5) Slowly turn the handle of charging gauge clockwise to set charging pressure and turn handle of N<sub>2</sub> gas cylinder clockwise.
- (6) Turn the handle of charging gauge counterclockwise, and then turn the handle of N<sub>2</sub> gas cylinder counterclockwise to close.

**NOTICE**

- For N<sub>2</sub> gas sealing pressure, refer to Fig.5-7-2.

- (7) Close the cap of charging gauge after gas hose is relieve from charging gauge.
- (8) Recheck charging pressure in back head as turning the handle of charging gauge clockwise.

**NOTICE**

- **When nitrogen gas is charged in back head completely by following procedures (1) through (8), disconnect charging gauge from charging valve of back head after the handle of charging gauge counterclockwise, but, if need to adjust the pressure of charging gas in back head by following procedures (9) through (13 ) mentioned below.**

- (9) Disconnect the gas hose from charging gauge.
- (10) Install charging gauge on charging valve of back head completely.
- (11) When turn the handle of charging gauge clockwise, gas pressure in back head is indicated on pressure gauge.
- (12) If gas pressure is low, again perform operations (1) through (8), repeat until gas pressure rises to specified pressure.
- (13) If gas pressure is excessive, slowly turn the adjuster of charging gauge counterclockwise, then gas pressure leaks from back head. When correct amount of gas pressure is shown, close the adjuster clockwise.  
When gas pressure is excessively high, breaker will not operate.  
Ensure that gas pressure is that specified pressure and O-ring in charging gauge is installed.

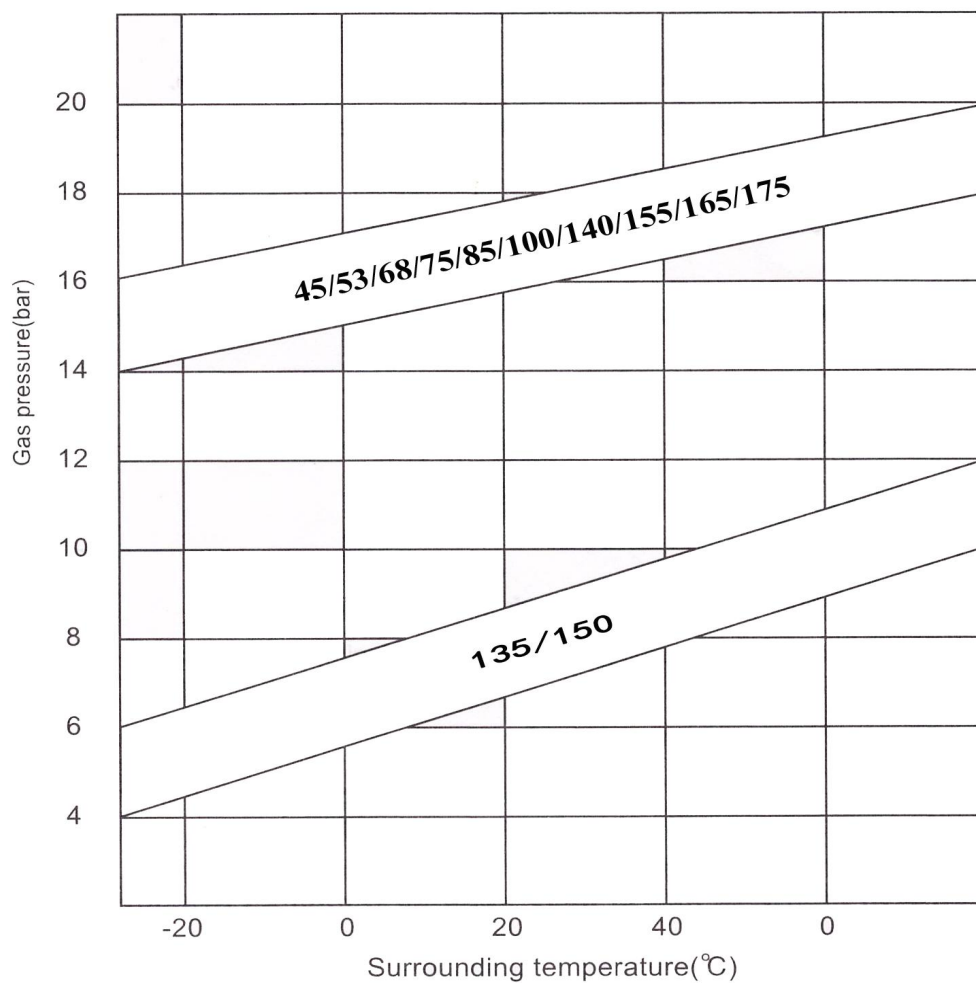

(Fig. 5-7-2)

Model	Charging Pressure (Kg/cm <sup>2</sup> )
45	16-17
53	16-17
68	16-17
75	16-17
85	16-17
100	16-17
135	6-7
140(A)	16-17
150	6-7
155	16-17
165	16-17
175	16-17

## 5-7-2. Accumulator

### ⚠ CAUTION

- **Must be tightened the accumulator body and accumulator cover before charging the nitrogen gas in accumulator assembly.**

### ⚠ WARNING

- **Use nitrogen gas only.**
- **The temperature of the hydraulic breaker main body must be normal when inspection or charging nitrogen gas of accumulator.**

### NOTICE

- **Be sure to use a charging gauge for charging the nitrogen gas.**
- **If the nitrogen gas is charged from gas cylinder without charging gauge, the diaphragm may damaged.**

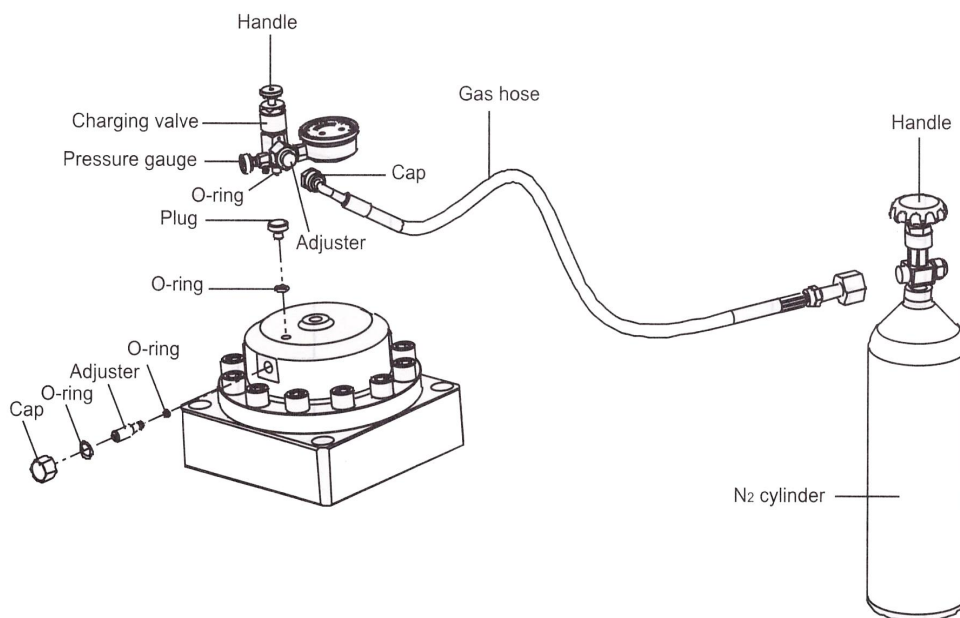

**A) Inspection of charging pressure**

- (1) Turn the handle of charging gauge counterclockwise.
- (2) Remove the A plug on the accumulator and charging gauge completely.
- (3) Remove the cap of adjuster from accumulator.
- (4) Turn the adjuster counterclockwise slowly to indicate accumulator charging pressure.
- (5) Remove charging gauge and tighten plug and cap.  
(Ensure O-rings must be installed in plug and cap).

**B) Charging accumulator with nitrogen gas.**

- (1) After performing steps same inspection of charging pressure.
- (2) Connect gas hose charging gauge and N<sub>2</sub> gas cylinder.
- (3) Turn the adjuster counterclockwise after remove the cap from adjuster.
- (4) Slowly turn handle of N<sub>2</sub> gas counterclockwise to charge accumulator with N<sub>2</sub> gas charging pressure.(refer in Fig.5-7-4)
- (5) When accumulator is charged with N<sub>2</sub> gas completely, close the adjuster fully.
- (6) Turn the handle of N<sub>2</sub> gas cylinder clockwise to close.
- (7) Loosen adjuster of charging gauge to discharge N<sub>2</sub> gas remaining in gas hose.
- (8) Remove the gas hose from charging gauge to N<sub>2</sub> gas cylinder.
- (9) After removing gas hose, adjuster the pressure referring **A) Inspection of charging pressure**
- (10) After charged accumulator with N<sub>2</sub> gas, check gas leakage from adjuster, plug hole of accumulator.

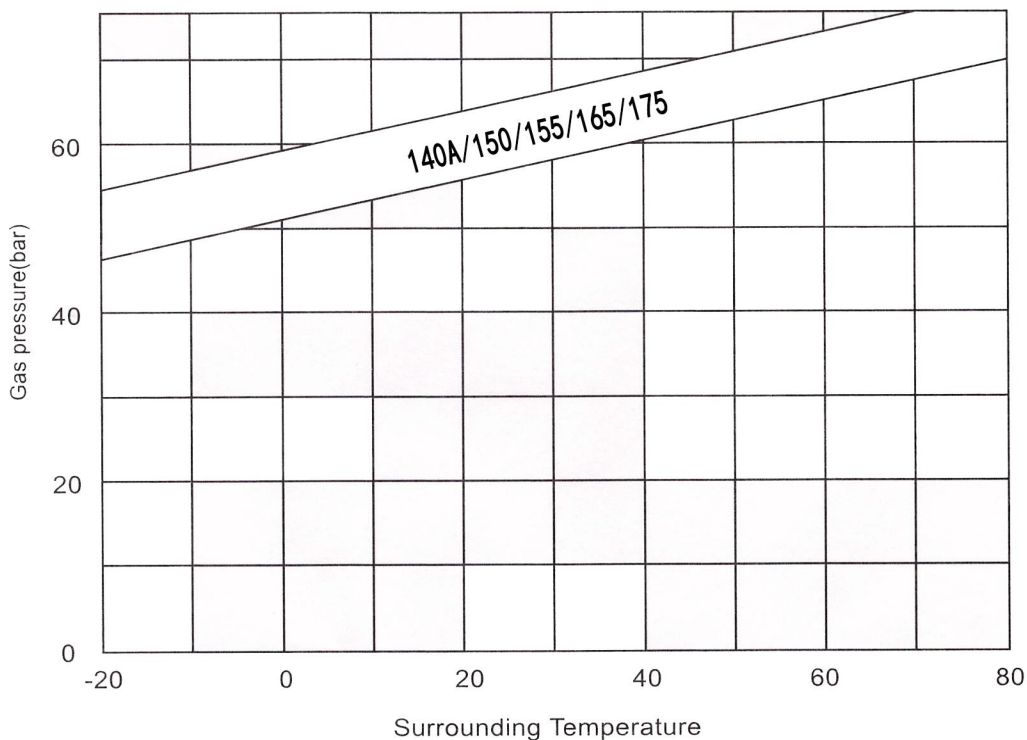

(Fig. 5-7-4)

## 5-8. Pressure setting

The pressure setting for hydraulic breaker must be lower than the base machine pressure setting in order to protect the pump of base machine.

Normally, set the pressure for hydraulic breaker about 5-10kg/cm<sup>2</sup> lower than base machine pressure setting, when the main pressure of base machine is lower than below table.

### **If hydraulic breaker setting pressure higher than below table:**

That will be shorten durable of main pump and shorten service life of seals & tool in hydraulic breaker.

### **If hydraulic breaker setting pressure higher than below table:**

Hydraulic breaker performance will be downed.

<b>Recommended setting pressure for hydraulic breaker (bar)</b>	
<b>45/53/68/75</b>	<b>160-180</b>
<b>85/100</b>	<b>160-180</b>
<b>140/140A</b>	<b>180-200</b>
<b>155/165/175</b>	<b>200-210</b>
<b>135/150</b>	<b>200-210</b>

## 5-9. Seal inspection

### **⚠ WARNING**

- Replace seals every 2000 hours of actual operation.

1) If any hydraulic oil leakage from hydraulic breaker is discovered, faulty seals should be replaced. To figure where seals are bad, refer to following drawings:

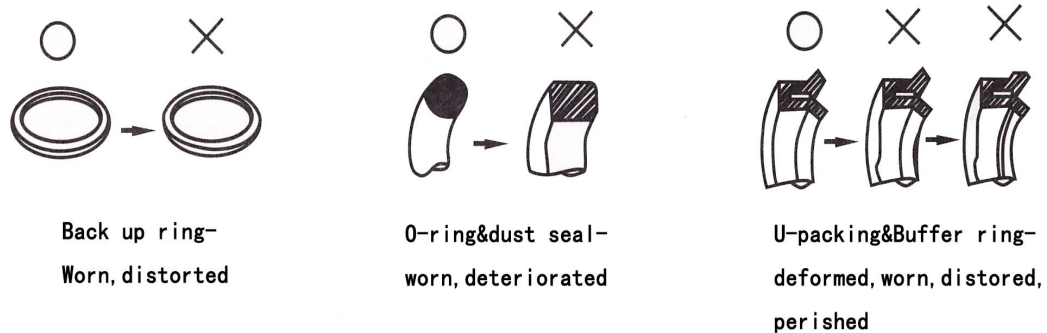

- 2) When bad seal is found, the cause of the damage must be determined and rectified.

When seal is changed, apply grease to seal and seal seat, and hold seal firmly with thumb, index and middle fingers, as per marking.

Be careful not to break seal through excessive deformation.

## 5-10. Wear inspection

### 5-10-1. Front cover

If the clearance between tool and front cover is too big, this could cause of damage, or breakage of tool through piston irregular contact.

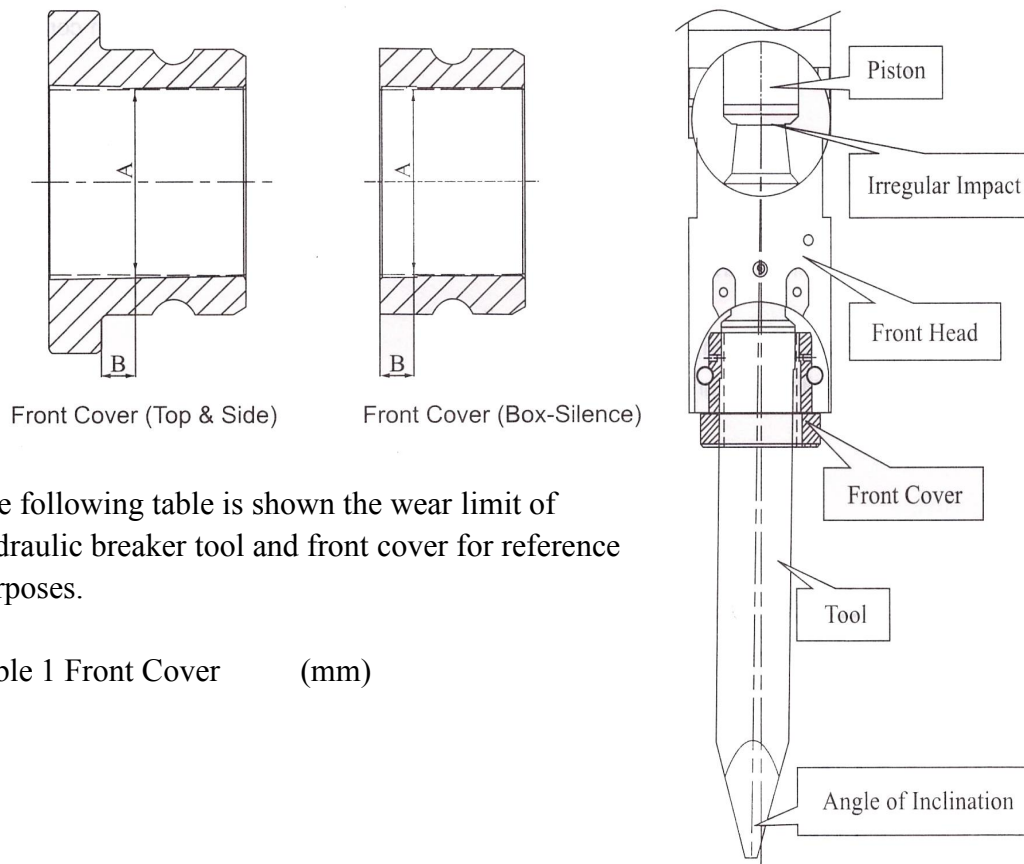

The following table is shown the wear limit of hydraulic breaker tool and front cover for reference purposes.

Table 1 Front Cover (mm)

Item	Model	Measure at B	Measure at A	Reject Inside Dia.
1	45	10	45	48
2	53	10	53	56
3	68	10	68	72
4	75	10	75	80
5	85	10	85	85
6	100	10	100	105
7	135	10	134.5	140.5
8	140(A)	10	140(A)	146
9	150	10	150	156
10	155	10	155	161
11	165(F)	10	165	172
12	175	10	175	182

**If the clearance between tool and front cover is too big, it could cause following problems:**

1. It could cause irregular impact and this may shorten the life of piston.
2. It could cause angle of inclination and this may be lead to the breakage of tool.

### 5-10-2. Tool Pin

#### NOTICE

- **Change the face of tool pins every 100 to 150 hours of actual operation.**
- **Replace tool pins every 500 hours of actual operation.**

- A) When each tool pin is excessively deformed, it is difficult to replace the tool, therefore, after operating the hydraulic breaker every 100 to 150 hours, change the face of each pin which comes in contact with the tool (The faces of each pin can be used).
- B) When replacing each tool pin, check each parts for wear, breakage, scores, etc., especially. And remove burrs and swelling on tool pins.
- C) Replace tool after grinding the worn parts of front cover and tool pins.

**When changing tool pins direction, place tool pins by opposite side.**

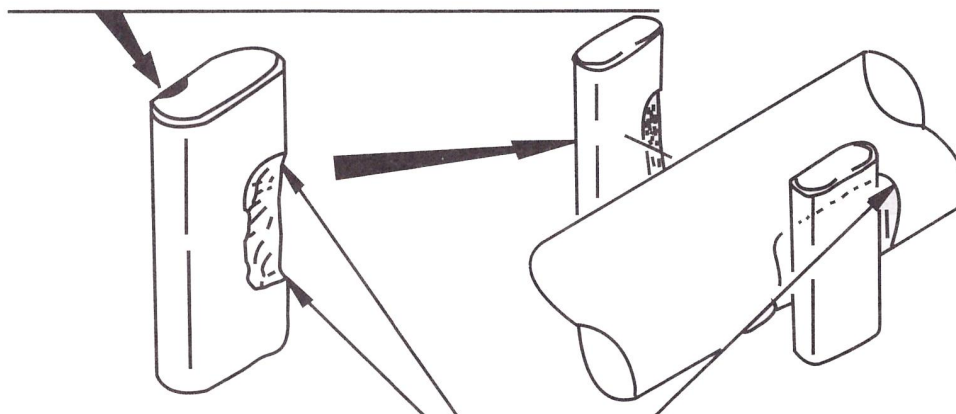

**Remove burrs and swelling  
with grinder or the like**

## 5-11. Inspection and replacement of through bolt

### ⚠ CAUTION

- **Discharge completely N<sub>2</sub> gas in back head prior to loosen through bolts.**

- 1) Discharge nitrogen (N<sub>2</sub>) gas in back head complete prior to loosen through bolts.
- 2) Remove all through bolts, and inspect for presence of any cracks and damages on through bolts.
- 3) When through bolts are assembled, tighten bolts one turn at a time in diagonal sequence; not each nut completely all at once turn of times, not completely at once.
- 4) Use to torque wrench of specified range. (Refer to torque table)

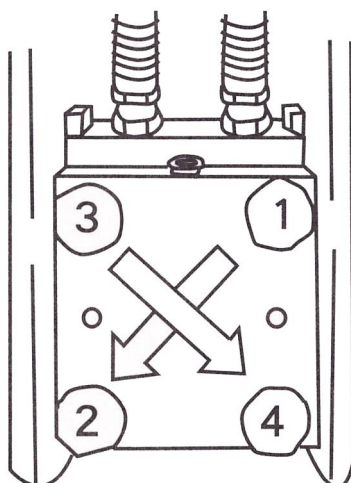

### 5-12. Torque table

- (1) Before starting the hydraulic breaker operation, check all kind of bolts and nuts for tightness including the through bolts, socket bolts for accumulator, valve housing socket bolts, valve cover socket bolts and bracket bolts.

Also be sure tighten again any loosen bolts and nuts according to the specified torque.

Using the hydraulic breaker with loose bolts and nuts will cause not only oil leakages but also damages to the screw threads and breakage to the bolts. These can lead also defective operation.

- (2) After first 10 hours of operating, retighten the bolts and nuts of all components and sections.
- (3) At first, lightly tighten the bolts and nuts by referring to the following torque force.

The bolts and nuts should be screwed down alternately and diagonally until the bolts and nuts are tightened to the uniform torque.

#### ■ Through bolt

Model	Torque (N.M)	Model	Torque (N.M)
45	500	140(A)	3200
53	700	150	3000
68	1200	155	3300
75	1300	165	3300
85	1600	165F	3500
100	2000	175	3500
135	2700		

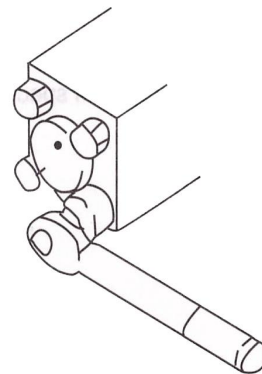

#### ■ Bracket bolt

Model	Torque (N.M)	Model	Torque (N.M)
45	350	140(A)	3000
53	400	150	3000
68	1200	155	3500
75	1200	165	3500
85	1300	165F	3500
100	2000	175	4000
135	3000		

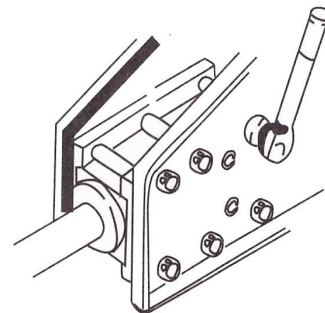

#### ■ Socket bolt - Valve cover

Model	Torque (N.M)
135	440
150	440

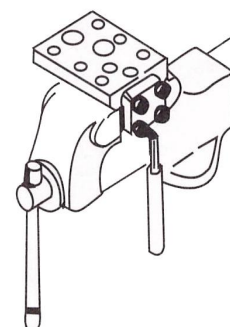

■ **Socket bolt - Valve housing**

Model	Torque (N.M)
135	440
150	440

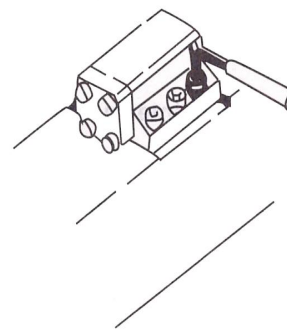

■ **Socket bolt – Accumulator cover**

Model	Torque (N.M)
140A	330
150	330
155/165	330
165F	330
175	440

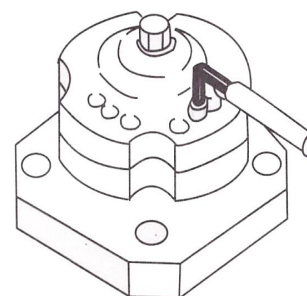

■ **Accumulator body**

Model	Torque (N.M)
140A	780
150	1565
155/165	440
165F	440
175	440

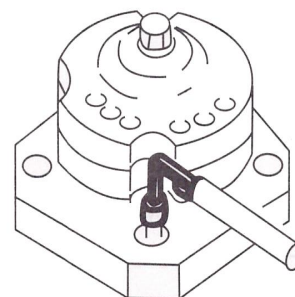

■ **Flange adaptor**

Model	Torque (N.M)
135	150
150	150

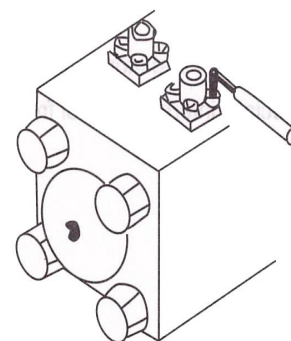

■ **Bolt-Mount cap**

Model	Torque (N.M)
135	750
140/140A	700
155	1300
165	1300
175	2000

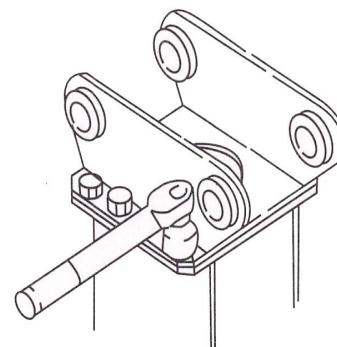

## 5-13. Storage

### ■ When operation is interrupted or finished

When operation is interrupted or after finished move the base machine on level ground. Remove mud from the hydraulic breaker and set the hydraulic breaker on wood blocks.

#### CAUTION

- **Do not touch the tool when hydraulic breaker just stop to work, because it's very hot.**
- Check whether oil leaks from hydraulic system and whether the tool oil is damaged.
- If the hydraulic breaker is operated in river, dry the hydraulic breaker body and apply the grease to the front head.

### ■ When hydraulic breaker is not used for a long time-3 weeks or more

#### CAUTION

- **If the following procedures are neglected, the rust is generated in the main body to cause serious troubles.**
- Discharge the nitrogen gas with the back head and accumulator, and then push the piston to avoid rust cylinder.
- Assemble the tool and store the hydraulic breaker indoors after applying the grease to every part, especially internal parts of front head.

## 6. Operation

Before starting the base machine which the hydraulic breaker is mounted, check to use the machine safely and to prevent any trouble.

### 6-1. Tool installation

#### ■ Installation

##### ⚠ CAUTION

- Personal injury can result from dropping the tool during replacement.
- Be sure to use a crane when handing the tool and such heavy parts.

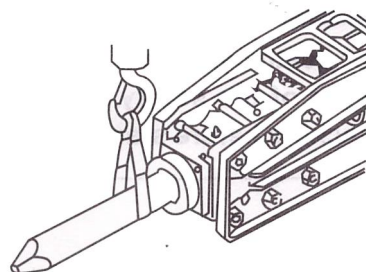

##### ⚠ WARNING

- Wear the safety shoes to protect feet.

- 1) Set the hydraulic breaker horizontally on wood blocks so that the accumulator may be upper side.
- 2) Remove the rubber plug or spring pin ① and the stop pin ② into front head from opposite side by using a hammer and a press pin. (Press pin is stored in tool box)

##### NOTICE

- Before tapping the stop pin, make sure that there is no person where they come out.
- After the rubber plug or spring pin ① removed and installed 2 or 3-times, the rubber plug ① by new ones.

- 3) Lift up the tool pins ③ after insert the press pin into the hole of tool pin from bottom side, and remove the tool pins from front head.
- 4) Insert the tool into front head.

##### NOTICE

- Apply the grease on the surface of shank area and impact area of tool.

- 5) Insert the tool pins, and then assemble the stop pin and rubber plug or spring pin in front head.
- 6) Using a hammer and a press pin, fasten the rubber plug or spring pin into front head.

#### ■ Removal

The removal of tool in reverse order of installation.

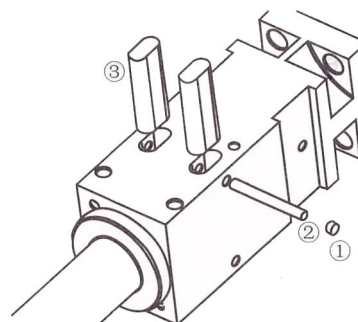

## 6-2. Safety operation

### 1) Precautions for safety operation

#### CAUTION

- Injury or death can result from improper operation or poor maintenance.
- Make sure of the safety from any trouble or any accident around the base machine before starting.

#### Inspection

Check the base machine and the hydraulic breaker to use safely and to prevent any trouble before operation.

#### Warming up the machine

Especially in winter or cold area , warm up the base machine at first before the breaker operation.

#### Safety maintenance

Before starting the work, examine the geological and geographical features of work site and be careful of the ground crack or the building collapse.

### 2) Cautions, when driving or stopping base machine

#### Driving

Carry out driving while the hydraulic breaker is kept horizontally with ground and is 40 to 50cm above ground.

#### Cautions on slope driving

When driving down on the slope, decrease the engine rpm and keep the angles with boom and arm 90° to 110°.

#### Stopping

When the machine is stopped, the hydraulic breaker stand vertically and set the tool end on the ground.

### 3) Safety operation

Stop working the hydraulic breaker, if hydraulic hoses vibrate excessively.

Check the N<sub>2</sub> gas pressure into accumulator & back head of hydraulic breaker.

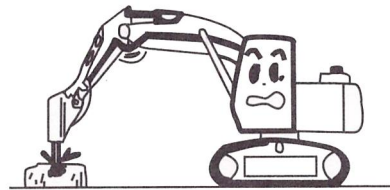

Stop the hydraulic breaker operation as soon as the object is broken. If operation continued, idle blows, could result in excessive wear of major components, or parts damage such as inner bush or piston.

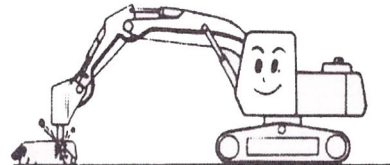

Do not use hydraulic breaker to move rocks with end of tool or with hydraulic breaker body.

Do not use tool as lever.

Hydraulic breaker could be damaged at through bolt, tool, front head, inner bush and front cover.

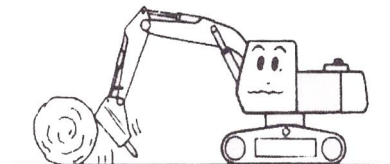

Move impact point of object, if the object does not break within 30 seconds.

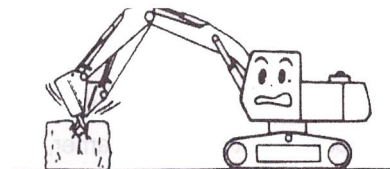

Do not use hydraulic breaker in water. Corrosion of hydraulic breaker, or non-lubrication, could result in further damage of the hydraulic components.

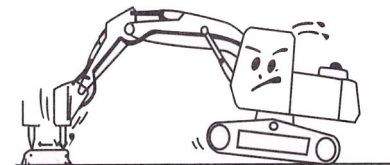

- Under water kit must be installed when hydraulic breaker for working in water.

Please contact to our dealer, if you need.

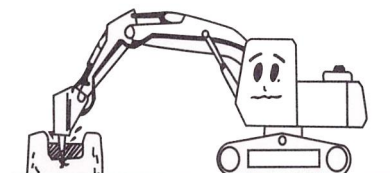

Do not use hydraulic breaker as hammering.  
Because of hydraulic breaker is much heavier than excavator bucket, such usage could result in damage of the front head or swing mechanism of the base machine.

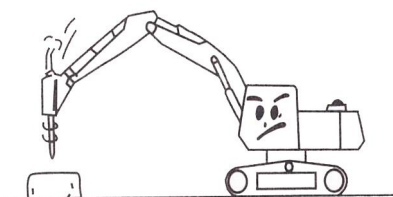

Do not operate hydraulic breaker with boom or arm cylinders fully extended (bottomed out).  
This may result in hydraulic breaker shock, and damage to the base machine.  
Maintain 100mm cylinder stroke of base machine at least.

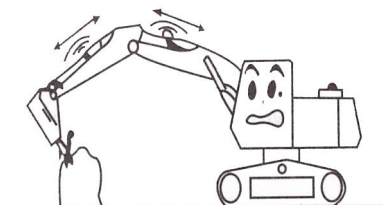

Do not curl the tool tip into arm or boom of base machine when travelling or parking carrier.

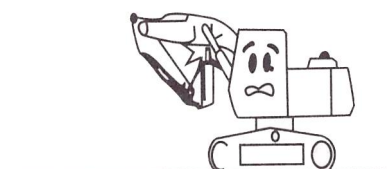

Do not strike in one spot for more than 30 seconds.  
If object does not break, stop breaking after than change the spot of object.  
Working too long in one spot will create excessive stone dust under tool. Dust dampens impact effect, and can be damage piston seal.

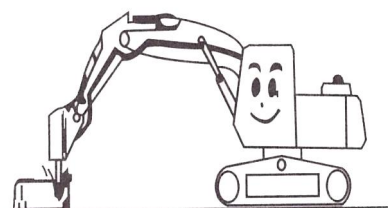

Never use hydraulic breaker as a transporter.  
This could result in tipping carrier, or damaging on base machine.

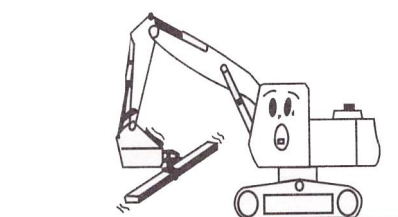

Operate the hydraulic breaker only to the front and rear of base machine.  
Do not use hydraulic breaker at either side of base machine.  
This may result in tipping excavator, or in damaging carrier swing device.

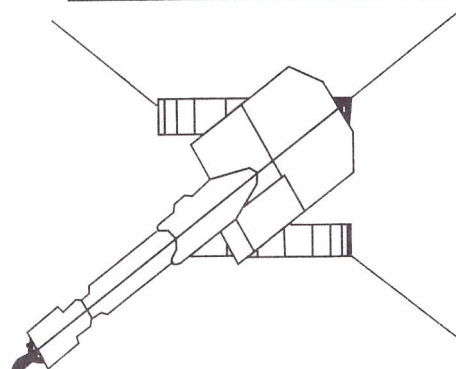

### 6-3. Function of adjuster (135/150/175)

#### 6-3-1. Cylinder adjuster

The hydraulic breaker is designed so that the bpm (blows per minute) can be adjusted with the operating pressure and oil consumption kept constant by changing the piston stroke, enabling the hydraulic breaker to be used widely.

However when the bpm is increased, the impact force will decrease.

Therefore the bpm must be adjusted in accordance with job condition.

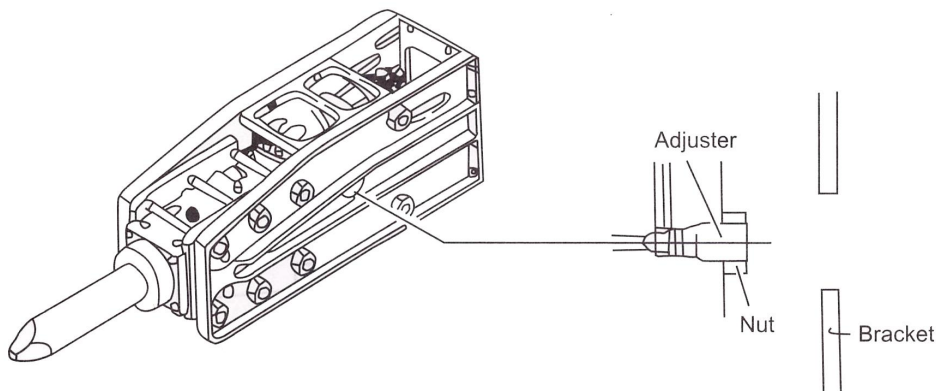

The cylinder adjuster is installed to the right side of the cylinder.

#### NOTICE

- **The cylinder adjuster is fully tightened when the breaker is delivered.**

When the cylinder adjuster is tightened fully, the piston stroke become maximum and the impact blows (bpm) becomes the minimum.

The other way, when the adjuster is loosened about two turns, the piston stroke becomes the minimum and the impact blows (bpm) becomes the maximum.

#### NOTICE

- **Even the adjuster is loosened over two turns, the impact blows does not increase.**

### 6-3-2. Valve adjuster

The valve adjuster is installed on the valve housing.

The impact blows and the oil consumption increase when the adjuster is opened and when it is closed, the impact blows and the oil consumption decrease.

When the oil flow from base machine is lower or when the hydraulic breaker has been installed on large base machine, the valve adjuster can control amount of oil flow artificially.

#### NOTICE

- The hydraulic breaker do not operate if the valve adjuster is fully closed.

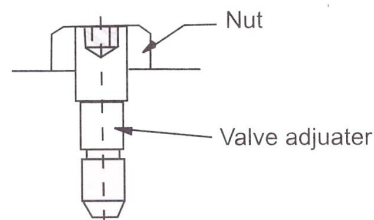
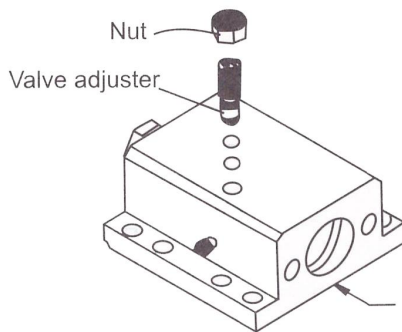

#### ■ Adjustment

Adjusting items	Procedure	Oil flow rate	Operating pressure	Bpm	Impact power	At delivery
Cylinder adjuster	Open	No change	No change	Increase	Decrease	Full closed
	Closed	No change	No change	Decrease	Increase	
Valve adjuster	Open	Increase	Decrease	Increase	Decrease	2-1/2
	Closed	Decrease	Increase	Decrease	Increase	Turn out
Charging pressure in back head	Increase	Decrease	Increase	Decrease	Increase	Specified
	Decrease	Increase	Decrease	Increase	Decrease	

## 7. Trouble-Shooting

This trouble-shooting guide has been prepared to aid the operator to locate the problem cause and then remedy when trouble has occurred. If trouble has been caused, obtain details as following check points and contact your local service shop or distributor.

### NOTICE

- **Check below mentioned items and contact service shop to check and repair any item which operator cannot remedy.**

### ■ Check point

Check point (Cause)	Remedy
1. Spool stroke is insufficient. After stop engine, depress the pedal and check if spool moves full stroke.	♦Adjust pedal link and control cable joint.
2. Hose vibration becomes bigger at hydraulic breaker operation. ♦High pressure line oil hose vibrate excessively. (Accumulator gas pressure is lowered) ♦Low pressure line oil hose vibrate excessively. (Back head gas pressure is lowered)	♦Recharge with nitrogen gas or check. ♦Recharge with gas. If accumulator or back head is recharged but gas leaks at once, diaphragm or charging valve may be damaged.
3. Piston operates but does not strike tool. (Tool shank is damaged or seizing)	♦Pull out tool and check. If the tool is seizing, repair with grinder or change the tool and/or tool pins.
4. Hydraulic oil is insufficient.	♦Refill hydraulic oil.
5. Hydraulic oil is deteriorated or contaminated. ♦Hydraulic oil color change to white or no viscous.(white colored oil contain air bubbles or water.)	♦Change all hydraulic oil in hydraulic system of base machine.
6. Line filter element is clogged.	♦Wash or replace the filter element.
7. Impact rate increases excessively.(Breakage or maladjustment of valve adjuster or nitrogen gas leakage from back head. )	♦Adjust or replace damaged part and check nitrogen gas pressure in back head.
8. Impact rate decreases excessively.(Back head gas pressure is excess.)	♦Adjust nitrogen gas pressure in back head.
9. Base machine meander or weak at traveling. (Base machine pump is defective or improper set of main relief pressure.)	♦Contact base machine service shop.









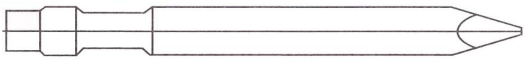

## ■ Trouble shooting guide

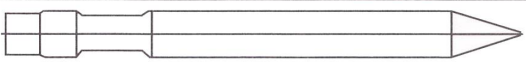
Symptom	Cause	Required action
No blow out	<ol style="list-style-type: none"> <li>Excessive nitrogen gas pressure of back head</li> <li>Stop valve(s) closed</li> <li>Lack of hydraulic oil</li> <li>Wrong pressure adjustment from relief valve</li> <li>Faulty hydraulic hose connection</li> <li>Hydraulic oil in back head infection</li> </ol>	<ol style="list-style-type: none"> <li>Re-adjust nitrogen gas pressure in back head</li> <li>Open stop valve</li> <li>Fill hydraulic oil</li> <li>Re-adjust setting pressure</li> <li>Tighten or replace</li> <li>Replace back head o-ring, or seal retainer seals</li> </ol>
Low impact power	<ol style="list-style-type: none"> <li>Line leakage or blockage</li> <li>Clogged tank return line filter</li> <li>Lack of hydraulic oil</li> <li>Hydraulic oil contamination, or heat deterioration</li> <li>Poor main pump performance</li> <li>Nitrogen gas in back head lower</li> <li>Low flow rate by mis-adjustment of valve adjuster</li> </ol>	<ol style="list-style-type: none"> <li>Check lines</li> <li>Wash filter, or replace</li> <li>Fill hydraulic oil</li> <li>Replace hydraulic oil</li> <li>Contact authorized service shop</li> <li>Refill nitrogen gas</li> <li>Re-adjust valve adjuster</li> <li>Push down tool by excavator operation</li> </ol>
Irregular impact	<ol style="list-style-type: none"> <li>Low nitrogen gas pressure in accumulator</li> <li>Bad piston or valve sliding surface</li> <li>Piston moves down/up to blank blow hammer chamber.</li> </ol>	<ol style="list-style-type: none"> <li>Refill nitrogen gas and check accumulator. Replace diaphragm if need</li> <li>Contact authorized local distributor</li> <li>Push down tool by excavator operation</li> </ol>
Bad tool movement	<ol style="list-style-type: none"> <li>Tool diameter incorrect</li> <li>Tool and tool pins would be jammed by tool pins wear</li> <li>Jammed inner bush and tool</li> <li>Deformed tool and piston impact area</li> </ol>	<ol style="list-style-type: none"> <li>Replace tool with genuine parts</li> <li>Smoothen rough surface of tool</li> <li>Smoothen rough surface of inner bush. Replace inner bush if need</li> <li>Replace tool by new</li> </ol>
Sudden reduction power and pressure line vibration	<ol style="list-style-type: none"> <li>Gas leakage from accumulator</li> <li>Diaphragm damage</li> </ol>	<ol style="list-style-type: none"> <li>Replace diaphragm if need</li> </ol>
Oil leakage from front cover	<ol style="list-style-type: none"> <li>Cylinder seal worn</li> </ol>	<ol style="list-style-type: none"> <li>Replace seals by new</li> </ol>
Gas leakage from back head	<ol style="list-style-type: none"> <li>O-ring and/or gas seal damage</li> </ol>	<ol style="list-style-type: none"> <li>Replace related seals by new</li> </ol>

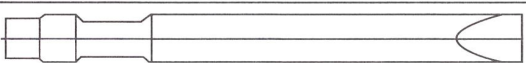
## 8. Tool selection

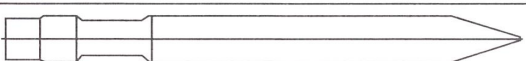

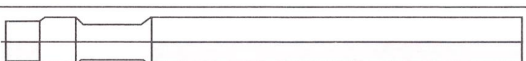
### 8-1. Guide to tool choice



- Tool Type

No	Type	Sketch map		Name	
1	Moil			Moil(universal) standard type we supply	M
2				Conical point	C
3	Chisel (flat)			H-Wedge	H
4				V-Wedge	V
5	Blunt			Blunt	B
<b>Note</b>		The drawings above are just for identifying different types of tool Tip			

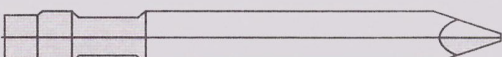

- Application Instruction

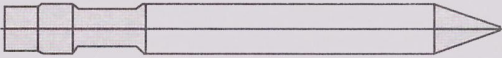

### Tool Dimension



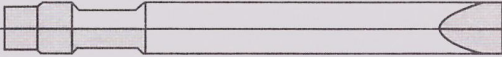

**Moil Point**  
This tool is suitable for common breaking work during which accurate control of the cut is not required.

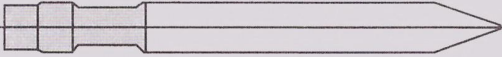
**Chisel Point**  
Most ordinarily used tool for demolition work. Available in both in-line and cross cut.

**Blunt Point**  
This tool is appropriate for breaking oversize material and concrete pads where a chisel point may go through too quickly.

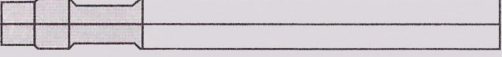
NO	Model	Dia	Lengt h	Weight
		mm	mm	kg
1	45	45	500	8
2	53	53	580	10
3	68	68	702	18
4	75	75	710	22
5	85	85	745	29
6	100	100	1055	57
7	135	135	1200	119
8	140	140	1300	136
9	150	150	1300	160
10	155	155	1500	190
11	165	165	1500	224
12	165F	165	1500	224
13	175	175	1600	260

### 8-2. Tool claim judgment

Hence, to help users use our products correctly, and ensure long operating life, these claim judgment criteria present defect examples that can occur during use, and the disposition standards applicable in each case.

■ **Breakage of piston impacting area or tool pins contact corners (Fig.1 and 2)**

Breakage of piston impacting point or of tool pins contact corners is extremely rare. This phenomenon occurs or when striking force is being concentrated on the tool corners due to unsatisfactory flatness of piston and tool impacting point. If such defect occurs, affected tools may not be accepted under warranty.

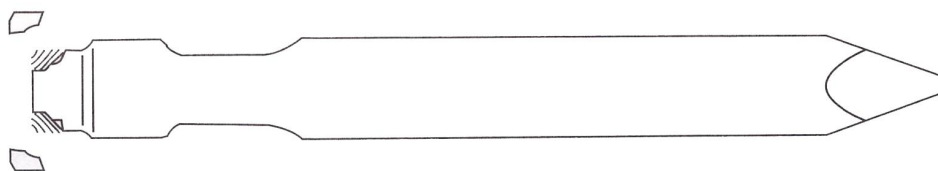

(Fig.1)

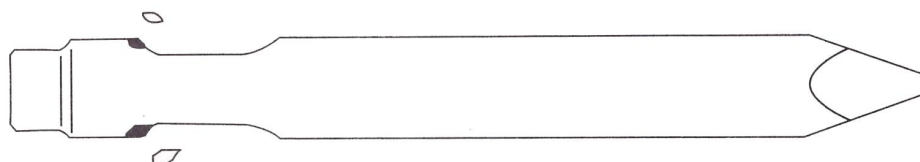

(Fig.2)

### ■ Plastic deformation of piston impact area (Fig.3)

The possibility of tool tip plastic deformation occurring due to piston is extremely slim. Such defects may occur due to material strength deficiency, or brittleness, resulting from unsatisfactory heat-treatment. If such defect occurs, affected products may be accepted under warranty.

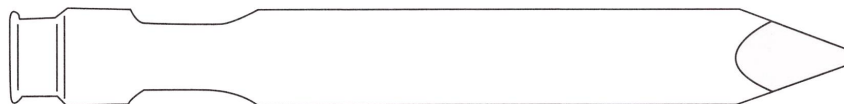

(Fig.3)

### ■ Breaking inside basic line (Fig.4 and 5)

Should product breakage occur in any direction at a point inside the front cover, as shown in <Fig.5>, from the basic line shown in <Fig.4>, this may be due to defective material, defective heat-treatment; tool deformation, or unsatisfactory shaping of tool neck. Should such defect occur, affected products may be adopted under warranty.

In addition to the causes described above, product breakage inside the basic line may also occur if the interval between the front cover and tool widens due to excessive wear of front cover, coupled with excessive bending load being applied to hydraulic breaker, if any trace of seizure, caused by friction between the front cover and tool, is observed on the surface of the tool body, and if it is clear that product breakage is centered around the area of such seizure, affected products may be rejected under warranty.

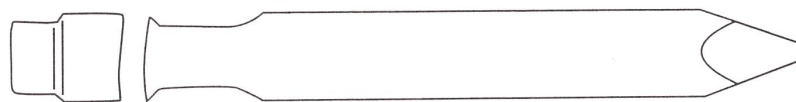
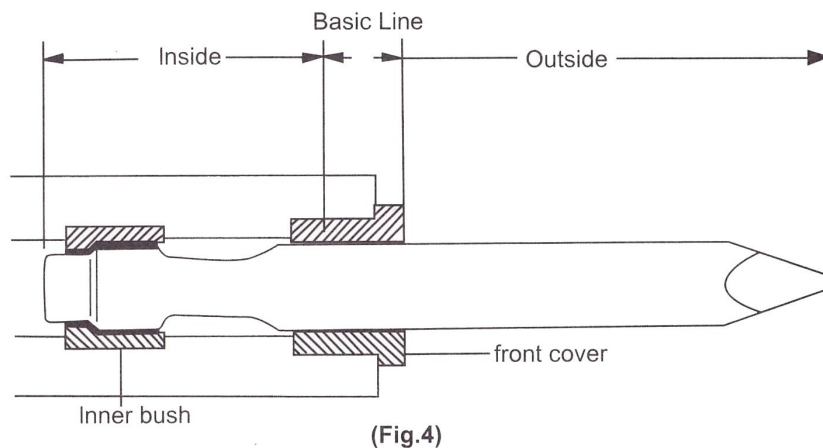

#### ■ Breakage outside basic line (Fig.6,7 and 8)

Should product breakage occur at a point outside the front cover, as shown in <Fig.6>, from the basic line shown in <Fig.4>, this may be due to excessive bending load being applied to the tool. Such bending load occurs when, after tool has been inserted into material, the tool is pulled or pushed, or when the tool is struck and pushed when it is not perfectly perpendicular to the surface of the material being worked on.

Fractures, in general, are of the form shown in <Fig.7>. Fatigue breakage, of clamshell form, develops in the areas near breakage start points, caused by stress concentration resulting from bending loads, and then quickly radiates outward, such type of breakage may also occur due to scarring of the tool body during use, as breakage occurring outside the basic line are caused by improper working habits, as explained above, products incurring such defects shall not be accepted under warranty. However, if a fatigue fracture start point occurs within the tool body, instead of on the surface of tool as shown in <Fig.8>, affected products will be accepted under warranty, as such breakage indicates material defect.

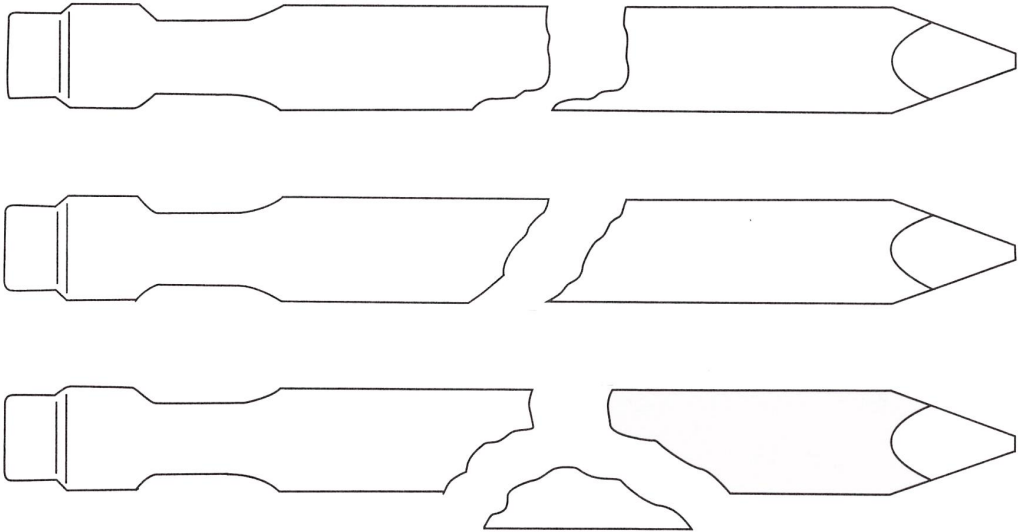

(Fig.6)

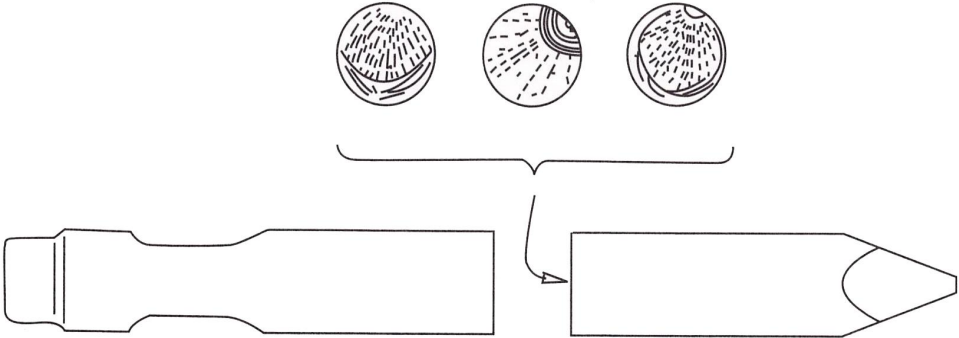

(Fig.7)

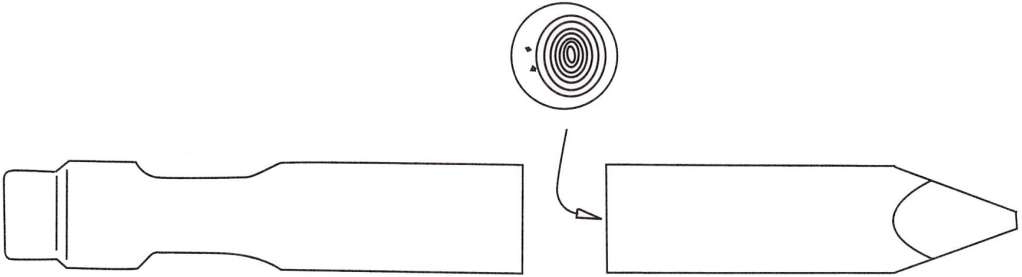

(Fig.8)

■ **Crushing of tool tip (Fig.9)**

Breaker tools are heat-treated to exhibit high breakage-and wear-resistance; and defects such as crushing of the tool tip <Fig.9> are not to be expected under normal operating conditions. However, if a tool is hammering continuously for a long period of time without crushing or puncturing the material being worked on, the temperature of the tip rises extremely high, inducing annealing of the heat-treated material, and bringing on plastic deformation(crushing), rather than wear, as explained above, crushing of the tool tip id caused by improper working methods, and, therefore, affected products will be rejected under warranty.

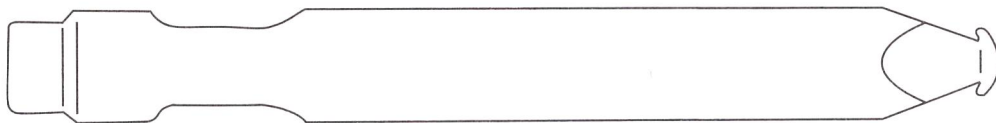

(Fig.9)

Tool tip wear (Fig.10)

The rates and types of tool tip wear vary with work material and work method. If the diameter of the worn tip of a chisel point tool is less than  $\frac{2}{3}$  of the tool body diameter, as shown in <Fig.10>; and if the tip of a new pointed tool is worn down in excess of 5mm lengthwise from the tip, this is considered normal tool wear, hence, tools exhibiting such normal wear, as shown in <Fig.10>, will be rejected warranty claim.

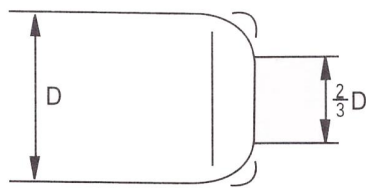

(Chisel point tool)

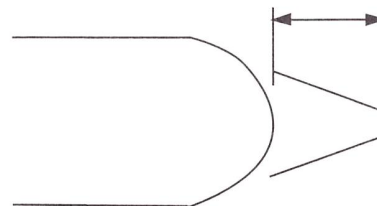

(pionted tool)

(Fig.10)